



luce x snac

INSTALLATION AND SERVICE

PROGRAMMING

This manual is for skilled service personnel only

IMPORTANT:

This automatic vending machine is not intended for use by persons with reduced physical, sensory or mental capabilities, or lack of experience and knowledge, unless they are supervised or instructed on the use of the vending machine by a person responsible for their safety. Children should be supervised to make sure that they do not play with the vending machine.

IDENTIFICATION, USE AND TECHNICAL DATA

This manual refers to **LXS9** series **LUCE X SNAC** automatic spiral vending machines, with number of drawers, number and type of vending spirals varying from model to model.

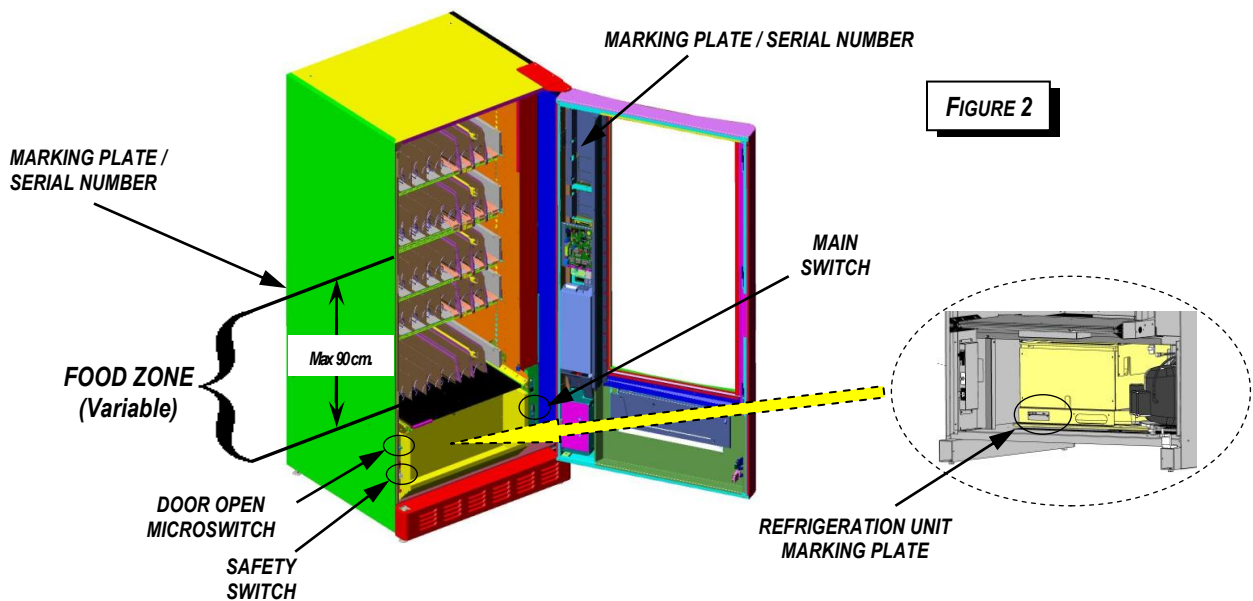
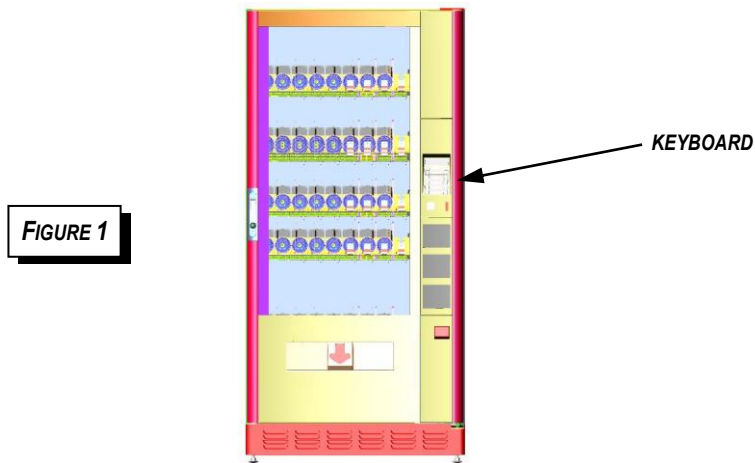

The intended use for **LXS9** series **LUCE X SNAC** automatic spiral vending machines consists of automatically distributing solid products or products in solid package; pre-packaged foods (snacks, bottled drinks, etc.) and non-food items.

For food products, make sure that the package is whole and that the products are in a good state of preservation in conformity with the current applicable regulations concerning the preservation of sold products.

The sale of toxic products (e.g. detergents) with food products is not allowed in the same vending machine.



The vending machine may not be used to sell explosive material or material at risk of fire.

These models are manufactured in variations "-A" without refrigeration unit and "-S" with *Super* refrigeration unit with the characteristics shown in the following table:

Characteristics	Variation	
	LXS9B/x/xx-A	LXS9P/x/xx-S
<i>Power supply</i>		
Voltage	220-230V~	
Frequency	50Hz	
Rated power	160 W	490 W
Max. Rated power	260 W	650 W
Protection	IP24 (Only suitable for covered and protected places where it cannot be rained on or sprinkled by water jets)	
Refrig. System version	Absent	Super
Minimum internal operating temperature	--	2 °C (*) Food zone only
<i>Environment</i>		
Storage temperature	0 ÷ 45 °C	
Working temperature	5 ÷ 32 °C	
Max. relative humidity	65 %	
<i>Dimensions and Weights</i>		
Height	185 cm +/- 1 cm	
Width	89 +/- 1 cm	
Depth	85 +/- 1 cm	
Maximum empty weight	300Kg	330Kg
<i>Noise level</i>		
The vending machine emits an A-weighted sound pressure level below 70 dB.		

(*) **Food Zone** = Variable height zone (up to a maximum of 90 cm) containing the drawers placed in the lowest position in the vending machine (See Fig. 2).

LEGEND OF SYMBOLS USED

Symbol	MEANING
	WARNING: NECESSARY OPERATION TO KEEP PEOPLE SAFE
	CAUTION: THE OPERATION CAN DAMAGE THE MACHINE OR CAUSE IT T MALFUNCTION

WARNINGS/CAUTIONS

The appliance should be started up by skilled service personnel **ONLY**.

All operations described in this manual, especially all maintenance operations concerning the electrical part, should be carried out by skilled technical service personnel **ONLY**.

The vending machine is equipped with a safety switch that allows powering up all electrical parts only when the door is closed. With this switch it is possible to power up the vending machine even with the door open, for example to perform the test procedure on the vending motors. Be careful that all moving parts (spirals, sliding anti-theft panel, etc.) are not accidentally activated.

This automatic vending machine is not intended for use by persons with reduced physical, sensory or mental capabilities, or lack of experience and knowledge, unless they are supervised or instructed on the use of the vending machine by a person responsible for their safety. Children should be supervised to make sure that they do not play with the vending machine.

 **Before checking any electrical part, move the *main switch* of the vending machine (See Figure 2) to the "OFF" position.**

UNPACKING

Unpack the vending machine as follows:

Cut the clear plastic wrapped around the packing box and remove the various protective corners.

Free the keys that are tied together with the power cord on the lower rear part of the vending machine.

To remove the wood supports, lift the vending machine using a suitable forklift truck (with a lifting capacity of at least 400 Kg and lifting height of 25 cm from the ground) and remove the metal brackets blocking the vending machine's feet by removing the fixing screws.

ASSEMBLY OF BASE PLATE (COVERING FEET)

There is a large package containing the base plate of the vending machine, inside the machine, between the door display window and the product drawers.

Remove the base plate from its packaging and position it under the door in front of the feet, pressing against the base of the vending machine.

The base plate will remain fixed to the base thanks to the magnetic hooks it comes with.

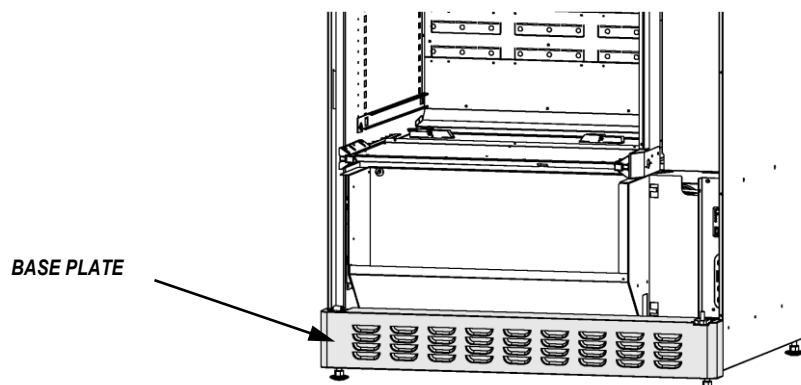

INSTALLATION

 **Install the vending machine in covered and protected places where it is not exposed to inclement weather and cannot be rained on or sprinkled with jets of water.**

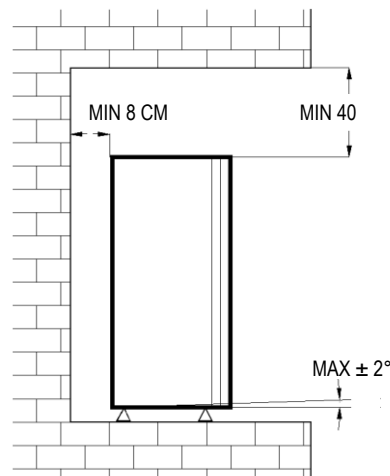

FIGURE 3

Place the vending machine in the point where it is to be installed, making sure that the minimum distances shown in Figure 3 are guaranteed.

Also make sure that air can circulate freely in the rear and upper part; the room should be ventilated regularly.

The vending machine must operate in a room that is in conformity with the information given in the table on page 3.

Using the vending machine outside of these conditions could cause it to malfunction.

Adjust the height and alignment of the vending machine by means of the support feet with a 19 mm open end wrench, making sure that all four of them rest correctly on the ground. When the vending machine is not levelled properly it can be difficult to close the door.

With the "wall anchoring bracket kit" accessory it is possible to anchor the vending machine to the wall with two special spacers (See Fig. 4), as follows:

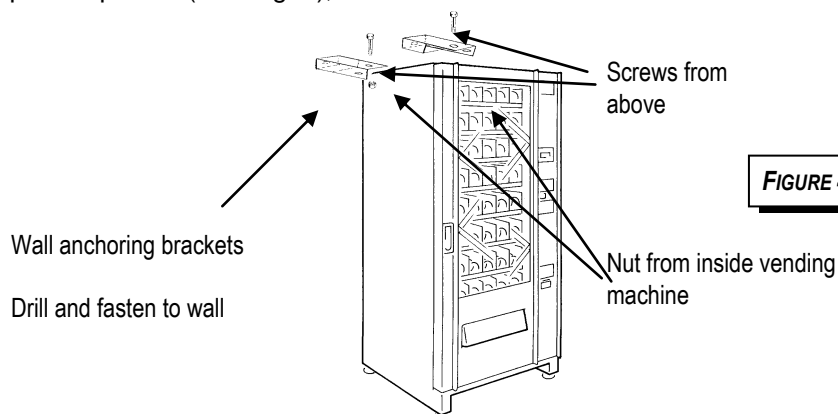

FIGURE 4

Screw the two "wall anchoring brackets" on the top of the vending machine (see figure) with the screw from above and a nut from inside the machine; remove the first drawer at the top to reach the position easily.

- Place the vending machine in the desired position and mark the position of the brackets on the wall.
- Drill the wall and fasten the brackets using expansion bolts, making sure that the brackets are positioned correctly.
- Position the vending machine inside the brackets and fasten it firmly with the screws from above and the self-locking nuts from below (inside the machine).

POWER SUPPLY



The vending machine should only be connected to earthed electrical systems.

Before connection to the supply mains, make sure that the earthing system is present, that the supply voltage is **220-230 Volt~**, that the outlet to which the machine will be connected is in good condition and approved for at least 10 Amp and that an omnipolar switch is installed upstream of it, i.e. that switches off both power supply conductors with a single opening action (except for the earth conductor), with an opening of the contacts of at least 3 mm. (It is recommended that the outlet have an insulated residual current breaker).

Install the vending machine so that the power-supply plug is easily accessible after you install it.

Check the appearance of the power cord to detect possible abrasions or other defects of the sheath or of the plug on the cord and replace it if necessary as described further on in this manual.

- POWER CORD REPLACEMENT

If it should become necessary to replace the vending machine's power cord, the H05VV-F replacement cord, which is in conformity with standard CENELEC EN 60 335-1, is available from Damian; the replacement should **ONLY** be carried out by **skilled service personnel**.



Before all operations on the power cord, make sure that the power-supply plug is disconnected from its outlet.

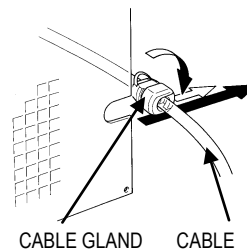
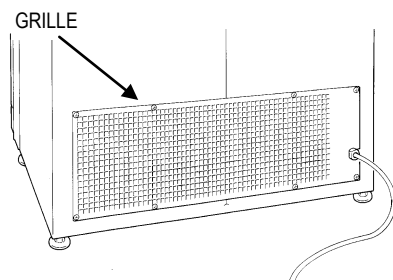

Remove the rear grille of the cabinet by unscrewing its fixing screws, remove the cable gland from the grille, open the cable gland and remove the cable.

Disconnect the cable socket from the electrical box and remove the cable to be replaced.

Repeat the operations described above in reverse order to install the new cable.

Check that the *main switch* found on the lower part of the cabinet (See Fig. 2) is in the "OFF" position and insert the plug into the power-supply outlet, then move the *main switch* to the "ON" position.

When the vending machine door is closed, all of its electrical parts will be powered owing to the pressure exercised by the door *on the safety switch* (black switch located on the left bottom of the vending machine. See Figure 2).

USING THE SAFETY SWITCH

The vending machine is equipped with a safety switch (See Figure 2) that allows powering up all of its electrical parts only when the door is closed. When it is necessary to power up the vending machine with the door open (for example, for loading products or programming), the safety switch can be armed by inserting the special key and turning it 90°. To disarm the safety switch (in order to cut off power to the electrical parts), turn the switch key 90° and remove it from the switch.

INSTALLATION OF PAYMENT SYSTEMS

 **The payment system installation and removal operations must be carried out with the power supply switched off, moving the main switch to the "OFF" position.**

- MDB PAYMENT SYSTEMS

Connect the payment system to the CPU card (2) being careful to connect the cable on the proper MDB connector on the CPU card (See Figure 5).

Turn the vending machine on and programme it for operation in MDB mode (as described in Attachment A, "Programming Sheet"); also refer to the documentation relative to the system itself for the MDB payment system settings.

Enter the selling prices and any other programming data (Refer to Attachment A, "Programming Sheet").

The vending machine is now ready for use.

- EXECUTIVE PAYMENT SYSTEMS (OPTIONAL KIT)

The Executive Kit (optional) must be installed for operation of the executive payment systems.

Connect the Molex 15-pin female power connector of the vending machine to the corresponding connector on the payment system (Refer to the payment system documentation).

Connect the serial connector of the payment system to the CPU card (2) using the special adapter cable, being careful to connect the adapter cable on the proper connector (See Figure 5).

Turn the vending machine on and programme it for operation in *Executive* mode (as described in Attachment A, "Programming Sheet"); turn the vending machine off and then on again and wait from 10 seconds to 2 minutes for communication with the payment system to be established. Remember to programme the "value of each step" parameter (also called "coin scaling factor" or "minimum coin") to the same value already entered during programming of the payment system (Refer to the payment system documentation).

Enter the selling prices and any other programming data (Refer to Attachment A, "Programming Sheet").

The vending machine is now ready for use.

CIRCUIT BOARDS, SLIDING PANEL, PRODUCT DOOR.

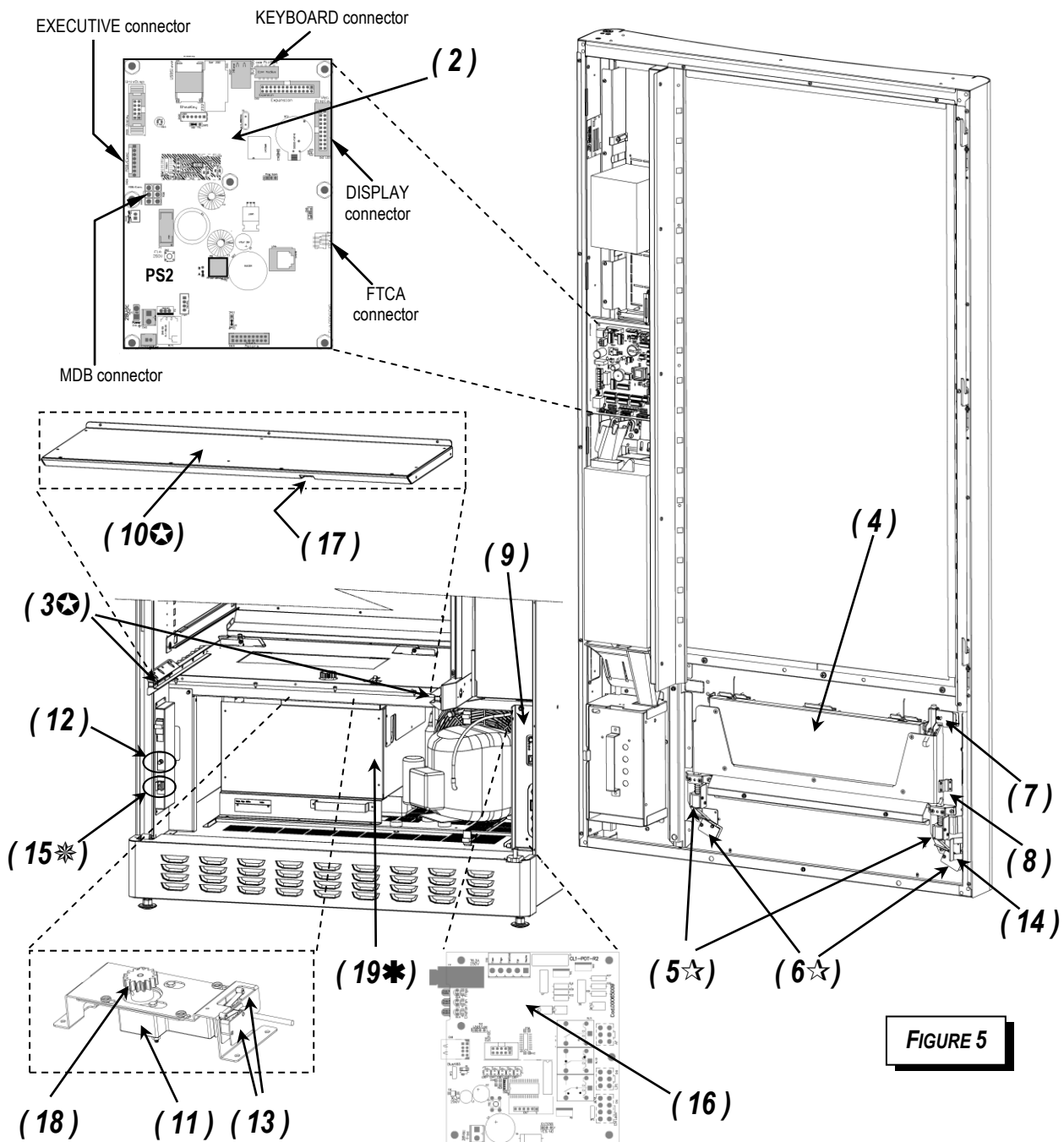

FIGURE 5

Legend		
(2) CL1 CPU circuit board	(9) Electrical box	(16) CLP1 POT circuit board
(3) FTCA sensor bars	(10) Anti-theft sliding panel	(17) Sliding panel rack
(4) External 'Push' product removal door	(11) Sliding panel motor	(18) Sliding panel motor pinion
(5) Two magnets for locking the 'Push' door	(12) Door open switch	
(6) Two microswitches of the 'Push' locking magnets	(13) Two beginning/end stroke microswitches	(19) Refrigeration unit
(7) Closing control microswitch	(14) Safety switch bracket	
(8) Magnetic sensor	(15) Safety switch	

OVERTEMPERATURE CONTROL (ONLY MODELS LXS9P/X/XX-S)

In order to guarantee the preservation of the products for sale, the vending machine controls that the internal temperature does not exceed a given threshold, called **safety temperature**, for a period longer than the **overtemperature time**;

The overtemperature control function is managed through 3 parameters:

- **(A) Safety temperature**
- **(B) Overtemperature time** (Set).
- **(C) Restocking time**

The overtemperature is only controlled in mode operating of the refrigeration unit = 'Food & Snack', setting the **(A) Safety temperature** parameter to a value below 40 °C

During normal vending machine operation, if the internal temperature exceeds the "Safety temperature" (A) for a period longer than the "Overtemperature time" (B), the "ERR L09" error will be generated, which will put the drawers set in the 'Food zone' of the vending machine out of order.

The period of time in which the vending machine is off is always considered beyond the "Safety temperature" (A).

If the vending machine is turned off and then on again (e.g. after restocking), the "Overtemperature time" (B) is prolonged by a value equal to the one set in the "Restocking time" (C) parameter.

Each time it is turned back on, if the internal temperature exceeds the "Safety temperature" (A) but the conditions for generating the "ERR L09" error have not occurred (see above), the following message will appear on the display for approx. 15 sec.:

Overtemp **XXX**Min
YY, Y --> **ZZ, Z** °C

XXX = Missing minutes,

YY, Y = Internal temperature,

ZZ, Z = Safety temperature.

(by missing minutes (**XXX**) we mean the minutes within which the internal temperature (**YY, Y**) must go below the safety temperature (**ZZ, Z**) to prevent generation of the "ERR L09" error).

If the "ERR L09" error has been generated, entering into programming you will be asked if you wish to reset the out of order by zeroing the error.

Reset ERR L09
(1) : YES (2) : NO

Press key **1** to reset the error

Press key **2** to NOT reset the error

IMPORTANT: the values of these three parameters should be set in accordance with the current regulations applicable to the preservation of sold products. See the programming parameters in Attachment "A" for how to set them.

N.B. To prevent false out of order indications following prolonged operator intervention, it is possible to initialise the counters through the "Overtemperature counter reset" function (Refer to Attachment A, "Programming Sheet").

ANSWERS TO PROBLEMS THAT MIGHT ARISE

- ERROR MESSAGES THAT APPEAR ON THE DISPLAY

The following table shows the OFF messages that appear on the display when the vending machine is out of order.

See Figure 5 for the numerical references in parentheses.

- **Press key "1" to display further details about the type of out of order reported in the error specification in parentheses.**
- **When any other key is pressed, automatic operation restoration will be attempted again, if possible.**

Message code	Message text	Problem description / solution
OFF L01...	Temperature probe 1 error – These messages indicate a problem with the probe that measures the temperature inside the vending machine . This probe is located on the inner right wall, near the 1 st low drawer towards the bottom of the vending machine. Note: Probe operation is only checked at the moment the vending machine is turned on.	
OFF L01a	Probe 1 defective	(Disconnected) – Probe 1 disconnected error. - Turn the vending machine off and then on again, verify in programming that the temperature value read by probe 1 is correct (see programming sheet). Try touching the probe; if the value shown on the display does not change, check the wiring and replace the probe if necessary. - If, once the probe has been replaced, the problem is repeated, the fault might be due to the CLP1 power board located in the electrical box.
OFF L01b		(Short-circuit) - Probe 1 short-circuited error. - Turn the vending machine off and then on again, verify in programming that the temperature value read by probe 1 is correct (see programming sheet). Try touching the probe; if the value shown on the display does not change, check the wiring and replace the probe if necessary. - If, once the probe has been replaced, the problem is repeated, the fault might be due to the CLP1 power board located in the electrical box.
OFF L02....	Temperature probe 2 error – These messages indicate a problem with the probe that measures the temperature of the refrigeration unit evaporator . This probe is located in the refrigeration unit located under the central plane of the machine. The refrigeration unit must be removed to access the probe (see specific chapter). Note: Probe operation is only checked at the moment the vending machine is turned on.	
OFF L02a	Probe 2 defective	(Disconnected) – Probe 2 disconnected error. - Turn the vending machine off and then on again, verify in programming that the temperature value ready by probe 2 is correct and that the probe is not immersed in ice; otherwise check the probe wiring and replace the probe if necessary. - Check the vending machine configuration to verify if this probe should be present. If not, carry out a new self-learning procedure as indicated in the programming sheet attachment. - If, once the probe has been replaced, the problem is repeated, the fault might be due to the CLP1 power board located in the electrical box.
OFF L02b		(Short-circuit) - Probe 1 short-circuited error. - Turn the vending machine off and then on again, verify in programming that the temperature value read by probe 2 is correct or that the temperature of the room is not above 45 °C. If the error is not reset, check the probe wiring and replace the probe if necessary. - If, once the probe has been replaced, the problem is repeated, the fault might be due to the CLP1 power board located in the electrical box.
OFF L04	Executive OFF	(Executive OFF) - No communication with the Executive system. - Check the 24Vac power supply coming from the transformer and the connection of the relative wiring with the 15-pin connector. - Check the Executive signal wiring. - If the problem is not resolved, check CPU card operation.

<i>Message code</i>	<i>Message text</i>	<i>Problem description / solution</i>
OFF L10...	FTCA vending sensor error – These error messages may appear when the vending machine is turned on or right before a sale.	
OFF L10a OFF L10b OFF L10c	FTCA sensors OFF	(Chk cable, Chang) – FTCA bars not connected - Check the condition of the wiring and of the connections of the FTCA bars (3) and replace wiring if necessary. - If the problem persists, replace the FTCA bars (3) one at a time, starting from the one on the right. - If the problem is not resolved, check CPU card operation.
OFF L10e		(Check LeftSensor) - Left hand FTCA bar error - Check the condition of the wiring and of the connection of the left hand FTCA bar (3) and replace it if necessary. - If the problem is not resolved, check CPU card operation.
OFF L10f		(Check RightSens.) - Right hand FTCA bar error - Check the condition of the wiring and of the connection of the right hand FTCA bar (3) and replace it if necessary. If the problem is not resolved, check CPU card operation.
OFF L10g		(High Light) - FTCA bars blinded error - Perform the vending sensor test. - Attenuate the possible source of external light that bothers the FTCA bars. - If the problem persists, replace the FTCA bar/s (3).
OFF L10h		(Low Light) - FTCA bar darkened error - Perform the vending sensor test. - Check the state of cleanliness of the FTCA bars (3), eliminating any elements that might obstruct passage of the light emitted by the LEDs. - If the problem persists, replace the FTCA bar/s (3).
OFF L12...		"Push" product removal door errors. These error messages concern failures of the opening and closing system of the external product removal door (4) (called "Push"). For a quicker check, perform the "Sliding door test" as explained further on.
OFF L12a	Door [Push]	(EMagnet. Fault) - Magnets for locking the "Push" door <u>short-circuited</u> One or both magnets (5) for locking the door are short-circuited. - Check their correct connection, the good condition of the wiring and/or replace them.
OFF L12b		(EMag. Disconn.) - Two magnets for locking the "Push" door <u>disconnected</u> The magnets (5) for locking the door are both disconnected. - Check their operation and relative wiring and replace them if necessary.
OFF L12c		(EMagnet. Error) - One magnet for locking the "Push" door <u>disconnected</u> One of the magnets (5) for locking the door is disconnected. - Check its operation and relative wiring and replace if necessary.
OFF L12d		("Push" Open) - "Push" product door <u>open</u> The microswitch (7) or the magnetic closing sensor (8) do not detect the actual closing of the "Push" door (4). - Check that the microswitch (7) and the magnetic sensor (8) are working, correctly connected and adjusted; make sure that the wiring is in good condition and replace them if necessary.
OFF L12e		("Push" Unlocked) - "Push" product door <u>unlocked</u> One or both microswitches (6) of the two magnets for locking the "Push" door do not detect the actual locking of the door itself. - Check that the pins of the magnets (5) can move freely. - Check that the product removal door (4) is closed properly. - Check that the two microswitches (6) are correctly connected and adjusted; make sure that the wiring is in good condition and replace them if necessary.
OFF L12f		(EMagnet Jammed) - "Push" product door <u>jammed (not released)</u> The microswitches (6) of the two "Push" door locking magnets do not detect the actual unlocking of the "Push" door (4) in spite of the activation of the magnets. - Check that the pins of the locking magnets (5) can move freely. - Check that the two microswitches (6) are correctly connected and adjusted; make sure that the wiring is in good condition and replace them if necessary.

<i>Message code</i>	<i>Message text</i>	<i>Problem description / solution</i>
OFF L13...	Sliding anti-theft panel errors. These error messages concern failures of the sliding anti-theft panel (10) closing/opening system.	
OFF L13a	Sliding Panel	(S.D. Mot. Fault) - Sliding panel motor <u>short-circuited</u> - Check the operation of the sliding panel motor (11) and the relative wiring; replace it if necessary.
OFF L13b		(SD Mot. Disconn.) - Sliding panel motor <u>disconnected</u> - You are attempting to make the sliding panel motor work with the door open when the open door switch (12) is not activated. Close the door or arm the switch to simulate the closed door. - If the door is closed, check the operation of the door open switch (12) and the relative wiring. Also check that the bracket (14) that presses the switch is adjusted properly. Replace the switch if necessary. - Check the motor (11) of the sliding panel (10) and the relative wiring. Replace it if necessary.
OFF L13c		(Sl.Door Removed) - Sliding panel <u>removed</u> Neither of the 2 beginning/end stroke microswitches (13) located near the motor are pressed. - Check that the sliding panel has been put back on after maintenance. - Check the operation of the 2 beginning/end stroke microswitches (13) and the relative wiring. Replace them if necessary.
OFF L13d		(Switch Exchanged) - Sliding panel microswitches <u>inverted</u> The CPU card (2) receives the closing signal when the motor (11) opens the sliding door (10) and vice versa. - Check that the beginning/end stroke microswitches (13) have been connected correctly after maintenance. - Check that the panel motor (11) power supply connection has not been inverted.
OFF L13e		(TimeOut SD Mot.) - Sliding panel error <u>during opening</u> At the end of an opening cycle, the sliding panel does not open completely or is not detected to be open. - Check that the sliding panel (10) can slide freely, that the guides are clean and that there is nothing preventing complete opening. - Check the operation of the opening microswitch (13) and the relative wiring. Replace it if necessary.
OFF L13f		(TimeOut SD Mot.) - Sliding panel error <u>during closing</u> At the end of an opening / closing cycle, the sliding panel does not close completely or is not detected to be closed. - Check that the sliding panel (10) can slide freely, that the guides are clean and that there is nothing preventing complete closing. - Check the operation of the closing microswitch (13) and the relative wiring. Replace it if necessary.
OFF L13g		(SD Mot Movement) – Sliding panel motor <u>movement error</u> You are trying to make the sliding panel (10) work but the motor (11) idles or is blocked. - Check that the motor block of the panel is hooked correctly. - Check that the motor gear (11) works correctly. - Check that the sliding panel (10) can slide freely.
OFF L20...	CL1 CPU (2) circuit board errors. These error messages concern failures of the vending machine's circuit board.	
OFF L20a OFF L20b	CL1 CPU Error	(Restart - Change) - CPU card error - Turn the vending machine off and then on again; if the problem persists, replace the CPU card (2).
OFF L20f OFF L20g		(Reinstall SoftW.) - CPU card software error - Turn the vending machine off and then on again; if the problem persists, update the software. - If the problem is not resolved after the update, replace the CPU card (2).

<i>Message code</i>	<i>Message text</i>	<i>Problem description / solution</i>
OFF L21...	CLP1 POT (16) circuit board errors.	These error messages concern failures of the vending machine's power circuit board located in the electrical box (9).
OFF L21a	CLP1 POT Error	(Chk cable, Chang) - CLP1 power board (in the electrical box) error - Turn the vending machine off and then on again; if the problem persists, check the connections between CPU (2) and electrical box (9); check the USB cable. - Open the electrical box and check the CLP1 card (16) power supply (the LED on the card must be lit up). - If the problem persists, replace the CLP1 power board (16).
OFF L21f OFF L21g	CLP1 POT SW Err.	(Reinstall SoftW.) - Power board (in the electrical box) software error - Turn the vending machine off and then on again; if the problem persists, update the software. - If the problem remains after the update, replace the CLP1 power board (16).
OFF L22a	Keyb-SENS Error	Capacitive keyboard card error - Turn the vending machine off and then on again; if the problem persists, check the connections between CPU (2) and the K-SENS capacitive keyboard. - If the problem persists, replace the K-SENS capacitive keyboard.
OFF L50 (xxxx)		Unforeseen generic error. - Turn the vending machine off and then on again; if the problem persists, contact the technical assistance service, providing the number in parentheses.

OTHER ANSWERS TO PROBLEMS THAT MIGHT ARISE



Before checking any electrical part, move *the main switch* to the "OFF" position (See Figure 7).

- MESSAGES RELATIVE TO MOTOR ANOMALIES.

During the selections or Diagnostic tests some motor anomaly messages might appear on the display; these messages are listed below with the relative explanation, as well as some possible solutions to the problem:

"Motor xx Disconnected" (NR)*: The motor is not connected to the CPU.

Check the connections and that the motor wiring is not interrupted.

Check correct operation of the motor microswitch and of the motor itself.

Try replacing, one at a time, the motor; the CPU card; the drawer and cabinet wiring.

"Motor xx Short Circuit" (NR)*: The motor is short-circuited.

Check the good condition of the motor itself.

Check that the motor and its connections are not wet.

Check the connections and that the motor wiring is not short-circuited.

Try replacing, one at a time, the motor; the CPU card; the drawer and cabinet wiring.

"Motor xx blocked" (R)*: The motor is blocked or absorbs too much current.

Check the correct assembly of the vending spiral.

Check the motor connections, especially the correct polarity of the power supply (+/-).

Check that the spiral or motor are not blocked by poorly arranged products or various residues.

Try replacing, one at a time, the motor; the CPU card.

"Motor xx Time Out Error" (R)*: The motor appears to work but the microswitch does not work correctly.

Check correct operation of the microswitch, of the motor and the good condition of the motor itself.

Check the motor connections, especially the correct polarity of the power supply (+/-).

Try replacing, one at a time, the motor; the CPU card.

"Motor xx Mot. Switch Err." (NR)*: The motor appears to work but functions anomalously.

Even if the error can be reset and the motor appears to work, if this error is repeated it is advisable to replace the motor.

If the error is repeated even once the motor has been replaced, the wiring must be checked;

"Motor xx Max 3 Selec Err." (R)*: The motor has been put out of order after three consecutive sales of the same motor without detecting that the product has dropped (See "FTCA Parameters" chapter).
Check that the spiral is hooked correctly to the motor.
Check the operation of the product drop control sensors (See "Diagnostics" chapter).

* = The error is automatically reset (R) or not reset (NR) upon turning on.

- UPON TURNING ON "OFFL13b (SD MOT. DISCONN)" IS DISPLAYED.

When the vending machine is turned on, you can not perform the test open / close of the sliding panel because the motor is not connected.

This error can occur even if you are attempting to make the sliding panel motor work with the door open when the open door switch (12) is not activated. Close the door or arm the switch, pulling the lever outwards, to simulate the closed door.

If the door is closed, check the operation of the door open switch (12) and the relative wiring. Also check that the bracket (14) that presses the switch is adjusted properly. Replace the switch or the bracket if necessary.

Check the motor (11) of the sliding panel (10) and the relative wiring. Replace it if necessary.

- UPON TURNING ON "ATTENZ. VERIFICA PANNELLO SCORREV." IS DISPLAYED.

When the vending machine is turned on, during the test of opening and closing the sliding panel, and wrong opening and closing times of the sliding panel values are found, it is suggested to perform a calibration of these values.

To calibrate sliding panel time/speed of opening/closing, enter into "Diagnostic" in the "Sliding panel test" menu (see relative chapter).

- UPON TURNING ON "WARNING OUT OF ORDERS DETECTED" IS DISPLAYED.

During normal vending machine operation, some malfunctions of some motors may occur. These malfunctions generate errors that can be automatically reset by the vending machine (R)* or that can be "not resettable" (NR)* and put the selection out of order (see above).

Even if operation of the selection has been automatically reset when the machine was turned on, the error remains stored and must be deleted manually in diagnostics to keep the message from reappearing.

To check which motors and which problems have been stored, enter into "Diagnostic" in the "out of order motors" menu (see relative chapter).

- WHEN MAKING A SELECTION "SELEC. X-X IN OVERTEMPERATURE" IS INDICATED

If some selections are out of order indicated by the "Selection xx in Overtemperature" message, this is due to the intervention of the "refrigerator safety control" (ERR L09 refrigeration unit timeout error) which has put the drawers set in the vending machine 'Food zone' out of order (see Overtemperature control" section).

Entering in programming, you will be asked if you wish to restore operation by resetting the error.

Reset ERR L09 (1) :YES (2) :NO

Press key **1** to reset the error
Press key **2** to NOT reset the error

When key **1** is pressed the selections will be active again.

- WHEN MAKING A SELECTION "SELECTION X-X NOT ACTIVE" IS INDICATED

If some selections are out of order indicated by the "Selection x-x not active" message, this indicates a problem relative to the storing of the configuration, because the selection made is not stored as active by the vending machine.

Make sure that you have made the correct selection.

Carry out the "Motor Verify" procedure found in the diagnostic menu.

Carry out a new self-learning procedure of the motors through the reset of the circuit board.

If the motor is not recognised during the self-learning procedure, see the relative error further on.

- WHEN MAKING A SELECTION "SELECTION X-X OUT OF ORDER" IS INDICATED

If some selections are out of order, indicated by the "Selection x-x out of order" message, this indicates the presence of a problem relative to the motor.

For a detailed analysis of the type of error that generated the out of order condition, use the "Diagnostic" menu, "out of order motors" submenu and the preceding chapter "Motor anomaly messages".

NOTE: It is possible to cancel the "Out of Order" condition of the motors without entering into programming by pressing the PS2 key found on the CPU card for approx. 3 seconds (See Fig. 7).

- SOME MOTORS ARE NOT DETECTED DURING THE SELF-LEARNING PROCEDURE.

Check the wiring and good condition of the unrecognised motors, as well as the good condition and correct insertion of the connectors on the bottom of the vending drawers.

After performing the above, carry out the procedure indicated for the "Disconnected motor" error.

- SEVERAL MOTORS RUN SIMULTANEOUSLY

When making a selection, two or more motors, even far apart, run simultaneously.

Check that a motor connection was not inverted following a maintenance operation. The motor with the inverted wiring might not be among those that rotate simultaneously.

Check the good condition of the wiring of the motors of the vending spirals.

Replace the motor and/or connection wiring if necessary.

Make sure that the "Twin motors" function is not activated.

If the problem persists, make sure that the CPU card works and replace it if necessary.

- THE MACHINE DOES NOT REACH THE REQUIRED TEMPERATURE



Before carrying out any operation on the refrigeration unit and, in particular, before checking any electrical part, move the *main switch* to the "OFF" position (See Figure 7).

Check the condition of the fuses (See the "Fuse check" chapter).

Make sure that dust and foreign materials do not block the refrigeration unit air passage.

Check that the condenser cooling fins are not blocked by dirt or foreign bodies and clean them if necessary (to access the refrigeration unit, see the "Refrigeration unit disassembly and reassembly" chapter).

Check that the set temperature is neither too high nor too low, referring to the programming sheet.

Check that the internal air circulation fan works correctly.

Check that the refrigeration unit compressor works and that the cooling fan (located between the compressor and the condenser of the refrigeration unit) works properly. If the compressor does not start working when the LED on the card indicates that it is activated, check and if necessary replace the electric starting capacitor, the Clicson or the amperometric relay located in the box mounted close to the compressor.

With the compressor operating, check that the evaporator actually gets cold.

Check that the two evaporator fastening hooks located on the shelf under the first drawer are closed and the evaporator properly hooked.

If it is not possible to identify the cause of the problem, contact an authorised service centre.

- DISASSEMBLY AND REASSEMBLY OF THE REFRIGERATION UNIT



Before carrying out any operation on the refrigeration unit and, in particular, before checking any electrical part, move the *main switch* to the "OFF" position (See Figure 7).

On the **LXS9** automatic spiral vending machines it is possible, with simple operations, to remove and perform maintenance on the refrigeration unit, extracting it from the front of the vending machine.

Follow the instructions given below to disassemble (See Figure 6 for the references given in parentheses):

- Open the vending machine door completely;
- Without removing it, pull out the first drawer on the bottom and unhook, turning them 180 degrees, the two hooks **(a)** that restrain the refrigerator evaporator to the lower shelf of the cabinet, reclose the drawer.
- Remove the product collection tray **(b)** by releasing the three push hooks **(c)** found at the sides of the tray;
- Remove the screw knob **(d)** that fastens the refrigeration unit to the base and disconnect the power supply wiring of the refrigerator from the electrical box;
- Grasp the handle **(e)** at the base of the refrigeration unit and remove it from the normal work position by pulling it, if necessary, until it is completely extracted.

To reassemble the refrigeration unit, follow the operations described above in reverse order, i.e.:

- Being careful not to damage the vending machine's power cord, centre the evaporator of the refrigerator in the guides of the cabinet shelf under the first drawer, slide the refrigerator on the vending machine base until it is back in the normal work position;
- Secure the refrigerator to the base with the special screw knob and reconnect its power cord to the electrical box.
- Reassemble the product collection tray, fastening it with the three push hooks found at the sides of the tray itself:
- It is very important to remember to reclose the two evaporator fastening hooks located on the shelf under the first drawer, otherwise you could compromise the correct operation and duration of the refrigerator;
- The refrigeration unit is now ready for use.

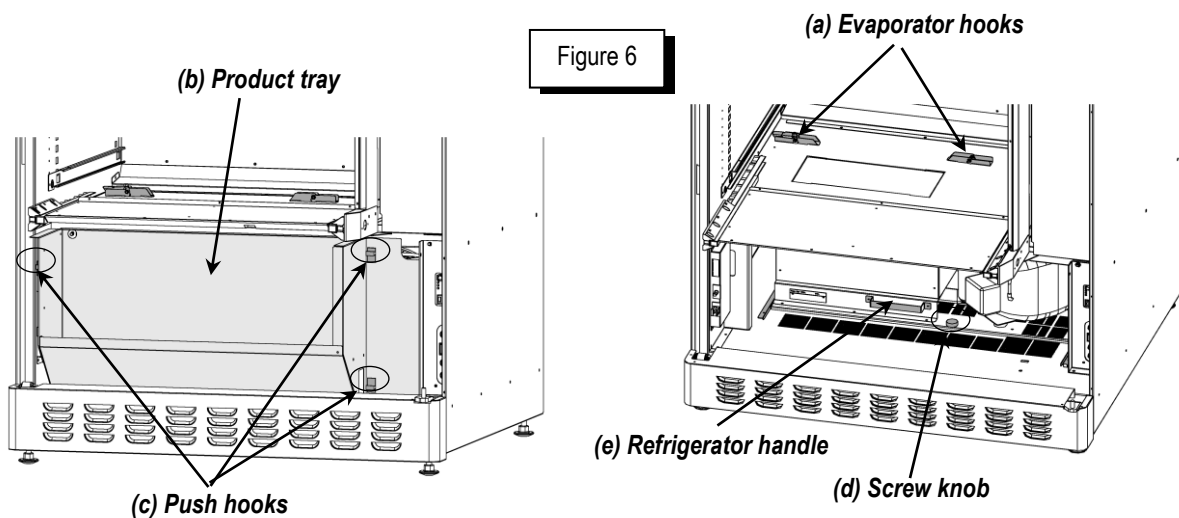

- FUSES

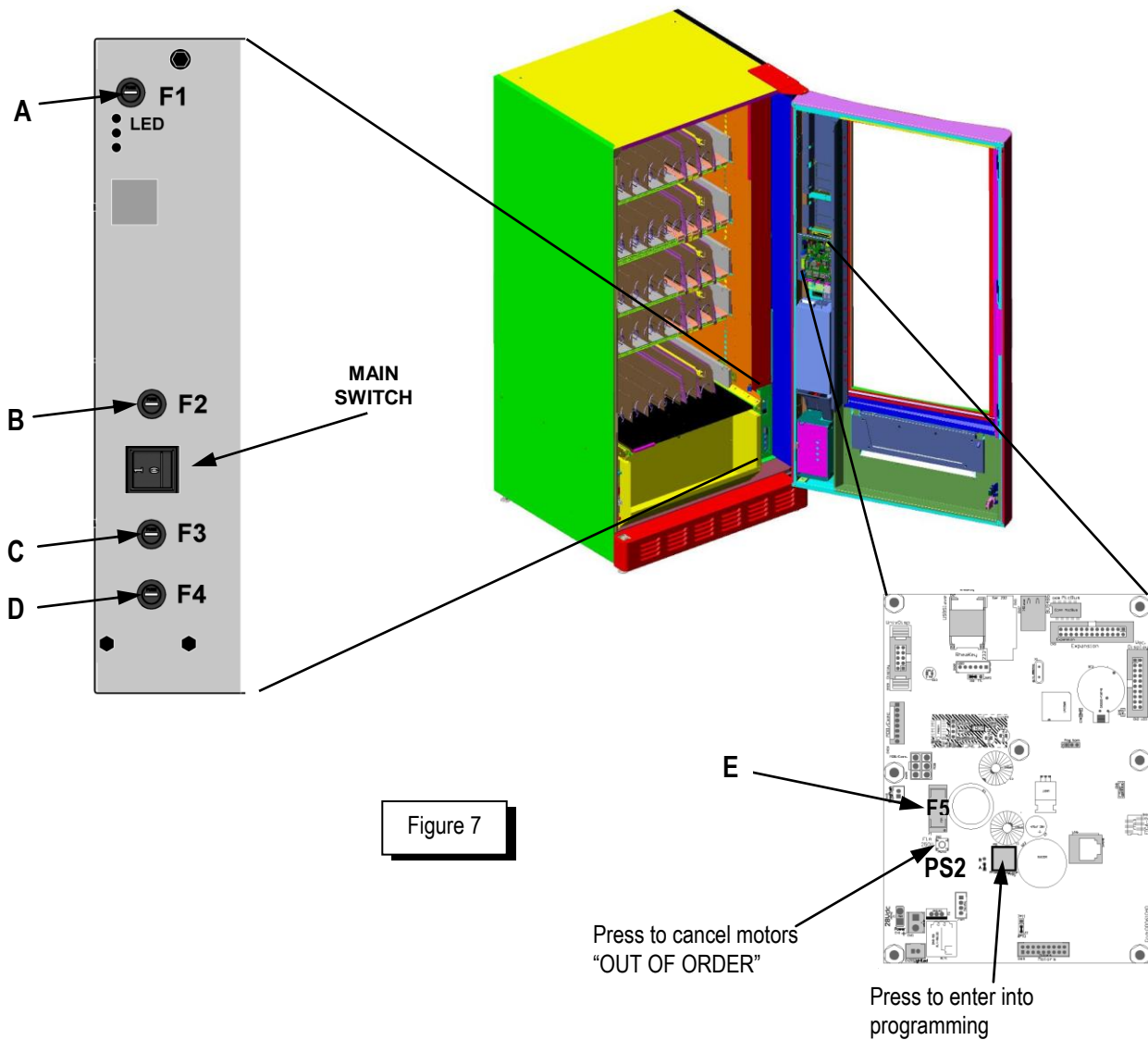

Figure 7

Press to cancel motors
"OUT OF ORDER"

Press to enter into
programming

The vending machine is equipped with fuses mounted as shown in the following table:

<i>POSITION</i>	<i>INSCRIPTION</i>	<i>TYPE</i>	<i>PROTECTED CIRCUITS</i>	<i>CHECK WHEN</i>
A	F1	5x20 T6.3 (6.3 A delayed 250 V)	Refrigeration unit	The vending machine does not refrigerate
B	F2	5x20 T6.3 (6.3 A delayed 250 V)	General 24-28V	The vending machine does not work
C	F3	5x20 T6.3 ((6.3 A delayed 250 V)	General 230V	The vending machine does not work
D	F4	5x20 T6.3 ((6.3 A delayed 250 V)	General 230V	The vending machine does not work
E	F5	5x20 F1 (1A rapid 250 V)	CPU power supply	The vending machine does not work, the display does not turn on.

ROUTINE MAINTENANCE AND LUBRICATION



During the maintenance and lubrication operations, do not perform any operation other than those indicated.

See Figure 5 for the references in parentheses.

Symbol	Periodicity	Check	Lubricate
✱	1 month	- Correct operation of the door safety switch	
⊛	3 months	- Correct operation of the sliding panel closing and opening microswitches - Check/cleaning of vending sensors (FTCA)	Sliding panel motor pinion and rack
☆	6 months	- Correct operation of the product removal door microswitches and magnets.	
✱	1 year	- Check/cleaning of the refrigeration unit condenser fins. N.B. (cut the periodicity by half for installations in especially dusty locations)	

- SAFETY SWITCH CHECK (✱)



During the safety switch check, do not perform any operations other than those indicated.

Check correct operation of the safety switch (15) by opening and reclosing the door with the vending machine on; make sure that the vending machine turns off when the door is being opened and that it turns on again only after it has been closed completely.

- SLIDING PANEL CHECK AND LUBRICATION (⊛)

Sliding panel (10) operation can be checked by performing a door closing and opening test (see: programm.-> diagnostics ->Sliding panel test). The sliding panel must be removed, by releasing the lever that locks the movement motor, in order to check the good condition of the closing / opening microswitches (13) and to make sure that pinion (18) and rack (17) are correctly lubricated. If it should be necessary to lubricate rack and pinion, put a thin film of SKF LGMT3/1 grease or equivalent.

After having reassembled the anti-theft panel, check that it works correctly by performing a door closing and opening test (see: programm.-> diagnostics ->Sliding panel test)

- CHECK/CLEANING OF 'FTCA' VENDING SENSORS (⊛)

To clean the LED barriers of the FTCA system (3), which are protected/hidden by the sliding anti-theft panel during normal operation, it is necessary to open it, performing a sliding panel (10) opening test (see: programm.-> diagnostics ->Sliding panel test). After opening the sliding panel (10), use a brush to gently clean the LEDs (3), removing dust or dirt that might obstruct passage of the light emitted by the LEDs.

- CHECK OF PRODUCT DOOR MICROSWITCHES AND MAGNETS (☆)

Product removal door (4) operation can be checked by performing the door closing and opening test (see: programm.-> diagnostics ->Product door test). If necessary, it is possible to remove the magnet covering panel on the lower internal part of the door to inspect the microswitches (6) that lock the product door (4) and the closing magnets (5), in particular to check the condition of the levers of the microswitches and that the magnets can move freely.

After having reassembled the magnet covering panel, perform a door closing and opening test (see: programm.-> diagnostics ->Product door test)

- CHECK/CLEANING OF THE REFRIGERATION UNIT CONDENSER (✱)

Turn the vending machine off using the main switch, access the refrigeration unit as described in the "refrigeration unit disassembly and reassembly" chapter, inspect the condenser and clean it if necessary, removing any residues with a brush or suctioning/blowing air. Make sure that dust is not raised during these operations; turn the vending machine back on only after having replaced the refrigeration unit in its normal work position.

ENVIRONMENTAL PROTECTION

Dispose of the cleaning and lubrication materials used in conformity with the regulations in force.

Do not dispose of the equipment with domestic waste. Recycle this equipment to reduce pollution and to guarantee maximum environmental protection; the materials must be recycled in conformity with local, regional and state laws.

It is preferable to recover raw materials than to dispose of waste: equipment and packing should be ecologically recycled.

Illegal disposal of the product by the holder involves the application of the administrative sanctions provided for by the regulations in force.

1. In the European Union



If the equipment is marked on the outside with this symbol, it should not be disposed of with normal household waste.

Contact your local dealer for further information regarding disposal.

2. In countries outside the EU

If you wish to get dispose of this product, please contact the local authorities for information on the correct disposal method.

WARRANTY

Damian S.r.l. provides a warranty for its own products that is in conformity with the specific national laws.

The warranty begins on the date shown on the sales document.

The warranty does not include damage caused by natural wear, overload, improper use or any other breakdown not caused by a manufacturing defect.

The warranty conditions are given at the end of this manual.

luce x snac

Attachment "A"

PROGRAMMING SHEET

**This attachment is an integral part of the manual
and must remain with it**

PROGRAMMING METHOD

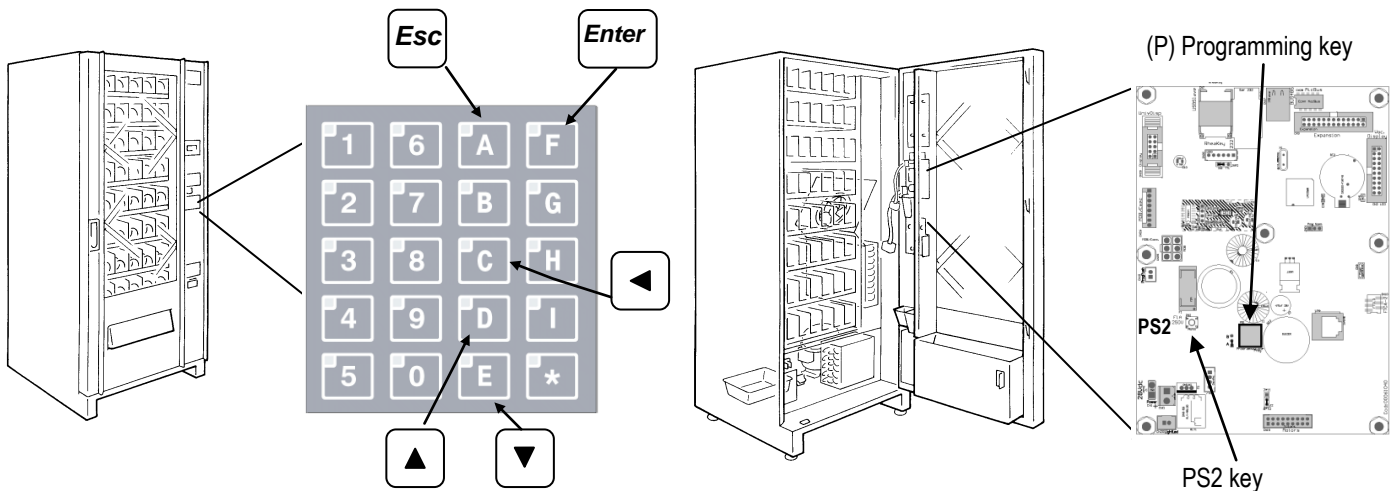



TO ENTER INTO PROGRAMMING



Open the vending machine, power it up using the special key on the safety switch and press the pushbutton (P) found on the CPU card of the vending machine (see the above figure) for about 2 seconds; avoid reclosing the vending machine so as not to damage the safety switch.

 When the safety switch is armed with the special key, do not perform any operations other than those described.

TO CHOOSE THE PARAMETER THAT YOU WISH TO PROGRAMME

Select the menu using keys **D** () or **E** (), the messages relative to the various menus will appear on the second line of the display.



When the message relative to the desired menu appears, press the **F (Enter)** key to confirm.

The parameter name will appear on the first line of the display, the currently set value on the second line. Select the menu parameter using the **D** () or **E** () keys; the messages relative to the various menu parameters will appear in sequence on the first line of the display, until it starts again from the first parameter.

When the message relative to the desired parameter appears, press the **F (Enter)** key to confirm.

TO CHANGE THE PROGRAMMED VALUE OF THE SELECTED PARAMETER

If "***>" appears on the second line followed by the current value.

Using the keyboard, write the desired value or press the **D** () key to increase or the **E** () key to decrease the current value.

Press the **F (Enter)** key to confirm and return to the previous point or press the **A (Esc)** key to exit typing without modifying the previous value.

Press the **C** () key to reset the proposed number.

In some cases press the **C** () key to move one digit to the left, until starting again from the first on the right. Once all of the digits have been entered, press the **F (Enter)** key to confirm and return to the previous point or press the **A (Esc)** key to exit typing without modifying the previous value.

TO EXIT PROGRAMMING

Press the **A (Esc)** key to return to the selection of the menus.

Press the "Programming key" (P) found on the CPU card of the vending machine for about 4 seconds or press the **A (Esc)** key for a few seconds.

In any case, if no key is pressed for more than 120 seconds you will automatically exit the programming phase.

DEFAULT = VALUE USED AUTOMATICALLY BY A NEW OR REINITIALISED CARD

GENERAL PARAMETERS

> MESSAGE LANGUAGE:

To establish the language of the messages that appear on the display.

[Default: Italian]

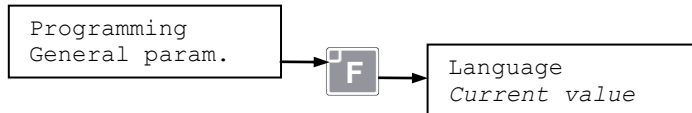

> OPERATING MODE:

To set the vending machine operating mode. Settable values:

'Test Vend' to operate in free sale, for example to perform the sale test.

'Executive' to operate with Executive payment systems;

'MDB' to operate with MDB payment systems;

[Default: MDB]

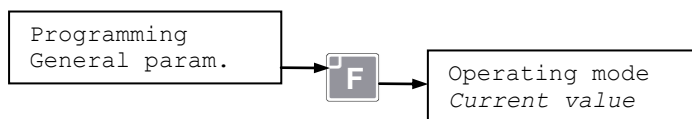

N.B.: Make sure that when setting the parameter to 'Test Vend', the vending machine allows sales of the products without deducting the credit.

> CLOCK SETTING:

To set the current date and time.

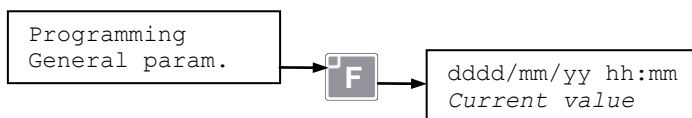

> CLOCK VISUALISATION ENABLE:

To activate or deactivate visualisation of the current time while the vending machine is awaiting a sale.

Settable values: 'Disabled' (OFF), 'Enabled' (ON).

[Default: enabled]

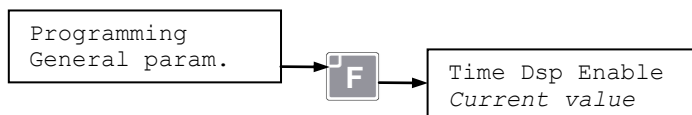

> ENERGY SAVING PROGRAMMING:

To activate and set the parameters of the energy saving functions, which are only available if the vending machine has the **Vivilight Kit** installed.

Energy Saving allows activating two separate energy saving functions:

- **Save Mode** function: Kicks in after a programmed vending machine inactivity time and reduces the electrical consumption of the vending machine working, for example, on the reduction of the lighting and the turning off of indicator lights and non-essential components.

- **Night Mode** function: Kicks in during programmed time intervals (for example, during nighttime hours) after a period of vending machine inactivity and reduces the electrical consumption of the vending machine to the minimum, working, for example, with the turning off of the lighting, of indicator lights and of non-essential components. Furthermore, if the vending machine is NOT programmed to contain perishable products ("Refrigerator operation" parameter other than "Food & Snack"), it allows setting a higher operating temperature only activated during those time intervals.

The energy saving function setting modes are given below.

» **SAVE MODE - ACTIVATION DELAY:**

(Visible and programmable only with Vivilight Kit installed)

This parameter allows setting the time in minutes that must elapse, without anyone using the vending machine, before the **Save Mode** function is activated (attenuation of the intensity of the LED lamps).
Settable values: **0 ÷ 120** minutes. Set the parameter to Zero '0' to deactivate the function.

[Default: 0 minutes]

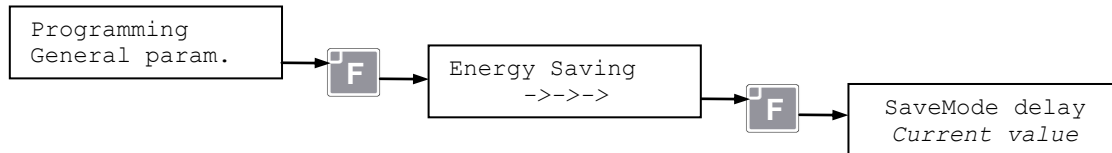

» **SAVE MODE - LIGHT INTENSITY:**

(Visible and programmable only with Vivilight Kit installed)

This parameter allows setting the luminous intensity (in %) of the LED lamps that light up the display window when the Save Mode function is activated. Settable values: **0 ÷ 100%** .

[Default: 100%]

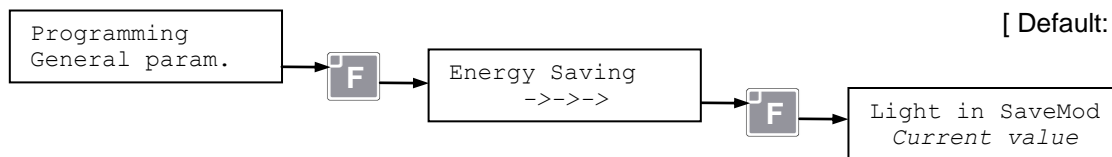

» **NIGHT MODE - TIMETABLE:**

(Visible and programmable only with Vivilight Kit installed)

This parameter allows setting the start and end times of the **Night Mode** function.
Set the times to **00:00 - 00:00** to disable the function.

[Default: 19:00 – 07:00]

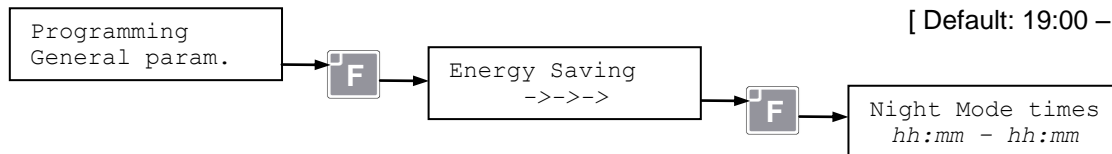

» **NIGHT MODE - LIGHT INTENSITY:**

(Visible and programmable only with Vivilight Kit installed)

This parameter allows setting the luminous intensity (in %) of the LED lamps that light up the display window when the **Night Mode** function is activated. Settable values: **0 ÷ 100%** .

[Default: 100%]

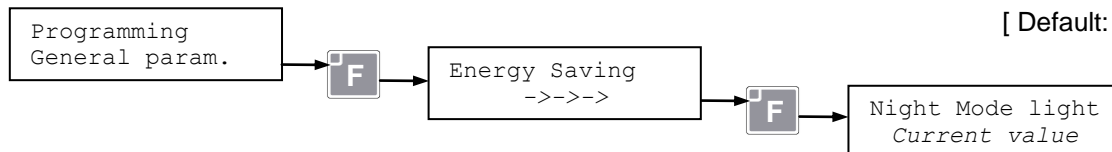

» **NIGHT MODE - INTERNAL TEMPERATURE SETTING:**

(Visible and programmable only with Vivilight Kit installed and "Refrigerator operation" other than "Food & Snack")

This parameter allows setting the internal temperature of the vending machine when the **Night Mode** function is activated. Settable values: **0 ÷ 50°C**.

[Default: 0°C]

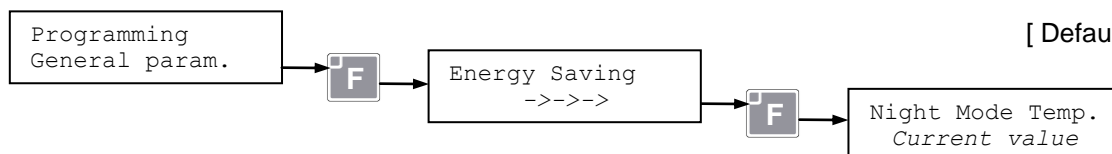

The refrigerator temperature raising function is deactivated during the **Night-Mode** period if the parameter is set to '0' (Zero) or to a value below the one set as standard internal temperature ('Set Std Temp 1' in the "Refrig. Param's" menu).

This parameter can also be programmed through the "Refrig. Param's" menu.

> REFRIGERATOR OPERATION:

(Visualisation only, programmable by reinitialising the card)

To visualise the operating mode of the refrigeration unit.

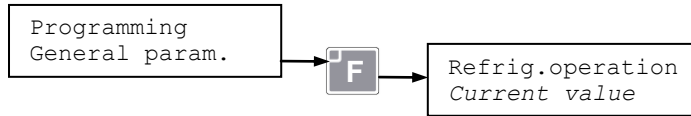

[Default: Self-learned]

The three possible operating modes, programmable by reinitialising the card, are:

- **Food & Snack**, enables management of the safety temperature for the Food zone.
- **Drink & Snack**, disables management of the safety temperature for the Food zone.
- **OFF**, disables operation of the refrigeration unit.

> FTCA PARAMETERS:

The series LXS9 vending machines can have an infrared system installed on the sides of the pick up tray for detecting actual passage of the product (Sale has occurred).

This infrared system comprises a pair of infrared LED barriers which, during normal operation, are protected/hidden by the sliding anti-theft panel, which is closed.

At each sale the FTCA barriers check the actual passage of the product; if it is not detected (Missed Sale), the vending machine maintains the credit and, if the "Enable + 3 step" mode is active, it attempts to make the spiral turn again by about 1/4 turn, repeating the operation 3 consecutive times. If these attempts also fail (or if the 3 step function is not active), the vending machine still keeps the credit stored in memory and allows a new selection to be made.

When this function is selected it will be possible to set the following parameters of the FTCA function.

» ENABLING FTCA VENDING SENSORS:

To activate operation of the vending sensors that check passage of the product.

Settable values:

- '0) Disabled', FTCA deactivated;
- '1) Enable NoStep' FTCA activated;
- '2) Enable + 3Step' FTCA activated + 1/4 turn management.

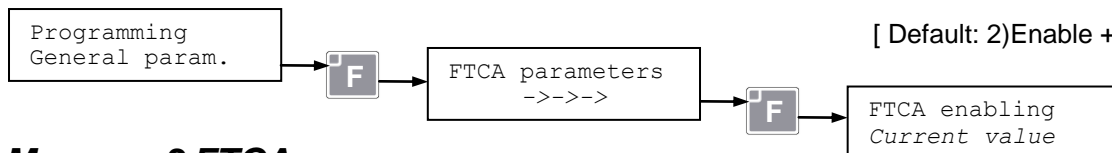

[Default: 2)Enable + 3Step]

» MAXIMUM 3 FTCA SELECTIONS:

In the case of a missed sale, allows making up to a maximum of 3 other selections without losing the credit. Settable values: 'Disabled' (OFF), 'Enabled' (ON).

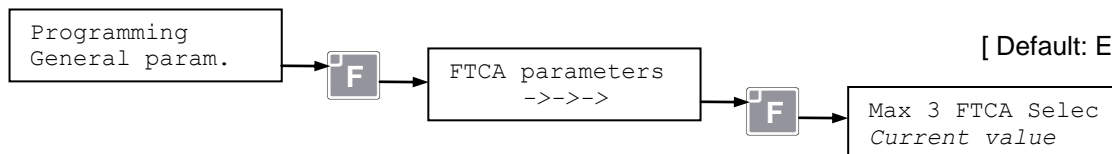

[Default: Enabled]

IMPORTANT: When this parameter is enabled, at the third consecutive sale of the same selection without detecting the product drop, the motor is put out of order and the credit deducted.

> DECIMAL POINT:

Sets the position of the decimal point on the display; used to indicate prices with parts in cents; the value 1 corresponds to 1 decimal (0000.0). Settable values: **0 ÷ 3**

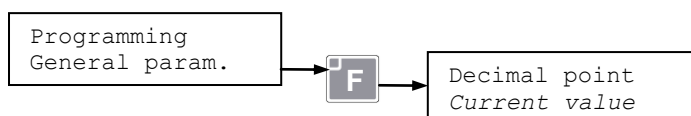

[Default: 2]

> **CODE MODE**

Allows to read the internal parameter software 'code mode'.

[Read only]

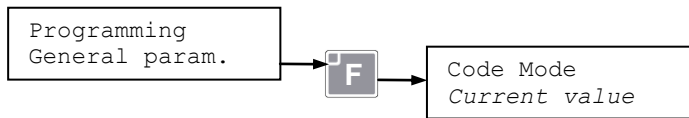

> **VISUALISATION OF THE SW VERSIONS INSTALLED:**

To visualise the software versions installed.

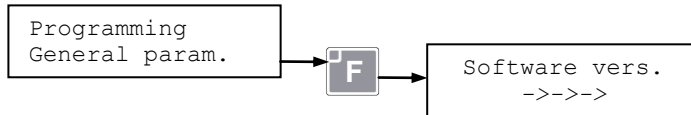

Press keys **D** and **E** to scroll through the versions of the various softwares.

> **CARD REINITIALISATION:**

To reinitialise the vending machine's CPU card, for example, after replacement with a new unprogrammed one.

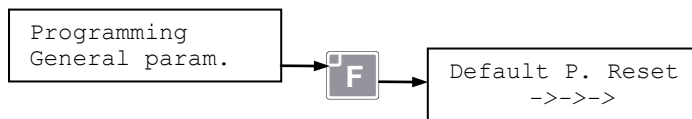

Proceed as follows to reinitialise the card:

- 1) enter into programming, **General parameters**, as described previously;
- 2) select **Default P. Reset**, this message appears on the display:

Password
00000

- 3) enter the value "**12345**" and confirm with **F**, the card will delete some of the stored programming parameters and will go automatically into "**self-learning**" mode.

The self-learning procedure occurs in the following phases:

Note: in the event of error in any point of the procedure, press the **A** key for a few seconds; the self-learning procedure will start over from the beginning.

- A)** This message appears on the display:

Self-learning
Language:Italian

after selecting the desired language, press **F** to confirm

- B)** This message appears on the display:

Self-learning
Conn. motors: xx

Check that the number of connected motors corresponds to those actually present in the vending machine; if there is a discrepancy, proceed as described in the installation and service manual in the "Answers to problems that might arise" chapter, "some motors are not detected" section.

press **F** to confirm

- C)** This message appears on the display:

Self-learning
Twin Motors:OFF

Press **F** if you do **not** wish to set twin motors in a single selection; Otherwise select '**Twin Motors: ON**' to set pairs of motors near each other that you wish to make run simultaneously with a single selection.

This message appears on the display:

Selection x-x
Current value

Select the motor that you wish to set coupled and press **F**.

When you have finished setting all of the motors that you wished to **couple (Twin Motors)**, press **A** to continue the self-learning procedure.

D) This message appears on the display:

```
Self-learning
FTCA sensors:XXX
```

If the product drop sensors (FTCA) **are installed** on the vending machine, **XXX = ON**

If the product drop sensors (FTCA) **are not installed** on the vending machine, **XXX = OFF**

press **F** to confirm

E) After a short time, the sliding panel will perform a cycle of opening and closing, if appears "OFF L13b SD Motor Disconnected", it is necessary to turn on the door open switch and press any button to check the open/close cycle.

Once the open/close cycle is complete, if any other problem is not found, you can pass directly to the "F" point, if wrong opening and closing times of the sliding panel values are found, there will appear the following message on the display:

```
Pannel. Scorrev.
1)Test 2)Skip
```

Press 1 key to perform the automatic calibration of time/speed of opening/closing of the sliding panel. At the end of the test the following message appears on the display:

```
O:xxx C:xxx Pxxx
TO:xxxx TC:xxxx
```

press **F** to confirm

F) The following message will appear shortly on the display:

```
Self-learning
Conn. probes x
```

Possible values: **0, 1, 2:**

If the value is '0' (zero), there is no refrigerator probe connected; the following message will appear when **F** is pressed:

```
Refrig.operation
OFF
```

With "OFF" mode, refrigerator operation is deactivated; the self-learning procedure ends when the **F** key is pressed and the vending machine returns to the programming menu. No other modes can be selected.

If the value is '1' (One), there is just one refrigerator probe connected; the following message will appear when the **F** key is pressed:

```
Refrig.operation
Drink & Snack
```

It is possible to confirm "Drink & Snack" mode or, alternatively, select the "OFF" mode.

In "Drink & Snack" mode, refrigerator operation is activated without management of the safety temperature of the food zone; the self-learning procedure ends when the **F** key is pressed and the vending machine returns to the programming menu.

If the value is '2' (Two), there are two refrigerator probes connected; the following message will appear when the **F** key is pressed:

```
Refrig.operation
Drink & Snack
```

or,

```
Refrig.operation
FOOD & Snack
```

It is possible to confirm "FOOD & Snack" mode or, alternatively, select the "Drink & Snack" mode or "OFF". Management of the safety temperature is activated when "FOOD & Snack" mode is selected; the following message will appear when the **F** key is pressed:

```
Security Temper.
*> 7.0°C
```

The safety temperature value is displayed with the possibility of changing it; press **F** to confirm.

If an incorrect message appeared on the display during phase F), carry out the operations described in the "Installation and service" manual, referring to the "OFF L01 and OFF L02" messages.

G) This message appears on the display:

```
Code Mode
*>   XXX
```

Self-learning of the internal parameter software 'code mode' : press **F** to confirm.

H) Once the last parameter has been confirmed, the self-learning procedure ends and the vending machine returns to the programming menu.

Reinitialisation allows keeping all of the other settings active (e.g. "product prices", "Price associations", etc.), avoiding reprogramming them.

Important: If it should be necessary to completely reset the circuit board with the total deletion of the programming parameters, the reinitialisation procedure described above must be carried out, entering the value "21613" in point 3).

» **PROTECTED PARAMETERS:**

Protected parameters are basic settings of the vending machine protected by 'Password', parameters that were set at the factory whose variation is not recommended unless suggested by the technical support service.

Improper variation of these parameters could compromise the correct operation of the vending machine.



RESETTING OVERTEMPERATURE COUNTERS

(Visible and programmable only with 'Refrigerator operation = Food & Snack')

If operator intervention is prolonged and the vending machine stays off or in overtemperature status for a length of time close to the time set, it is possible that at the end of the intervention, when the operator has already moved away, the vending machine is not able to bring the temperature back below the set threshold in the residual time remaining. To prevent false out of order indications after prolonged operator intervention, the various counters can be initialised through this function.

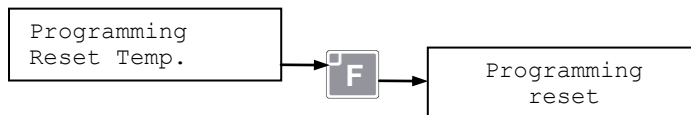

Important: This function must be used in conformity with the applicable regulations in force regarding the preservation of sold products.

MANAGEMENT OF SELLING PRICES

The series LXS9 vending machines can manage 44 price lines (i.e. 44 different prices), which will be associated with the individual vending selections available. These 44 prices comprise the 'A' price bracket, i.e. the basic prices that will be used as reference in the price-selection association.

For the LXS9 vending machines it is possible to manage a second bracket of another 44 price lines, the 'B' price bracket, to be used, for example, for sales made with payment systems to which we wish to assign dedicated prices, i.e. Cashless or RFID systems.

The prices of the 'B' bracket will automatically be associated with the same selections associated with the 'A' bracket (For example, if price line 1 of the 'A' bracket is associated with selection '2C', it will automatically be associated with price line 1 of the 'B' bracket also).

» **'A' BRACKET SELLING PRICES:**

The 44 available selling price lines of the 'A' bracket can be set as follows:



Press keys **D** and **E** to scroll through the available price lines (xx going from 01 to 44)

Press the **F** key to select the value "VVVVV" of the price line to be varied. Enter the new value, pressing the numbers on the keyboard, confirm the price by pressing the **F** key again.

Note: if the entered value is not an exact multiple of the "Min. coin values" parameter (see further ahead), it will automatically be rounded off and the new value will have to be reconfirmed with the **F** key.

Once the selling price lines have been set, they can be associated with the available selections with the 'Price association' parameter.

> ENABLING OF THE 'B' BRACKET SELLING PRICES:

(Visible and programmable only with 'Operating mode = MDB' and/or RFID payment system installed)

To activate or deactivate management of the second price line bracket ('B' price bracket).

Settable values: **Enabled** (ON), **Disabled** (OFF).

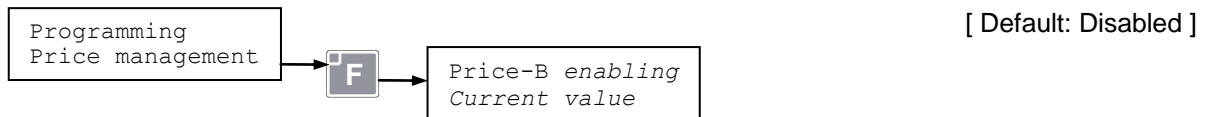

Activating management of the 'B' selling prices, it will be possible to set the prices of the second price line bracket.

» 'B' BRACKET SELLING PRICES:

(Visible and programmable only with 'Enabling B bracket prices enabled')

The 44 available selling price lines of the 'B' bracket can be set as follows:



Press keys **D** and **E** to scroll through the available price lines (xx going from 01 to 44)

Press the **F** key to select the value "VVVVV" of the price line to be varied. Enter the new value, pressing the numbers on the keyboard, confirm the price by pressing the **F** key again.

Note: if the entered value is not an exact multiple of the "Min. coin values" parameter (see further ahead), it will automatically be rounded off and the new value will have to be reconfirmed with the **F** key.

> PRICE ASSOCIATION:

This function allows associating a price of the 'A' price bracket and the respective 'B' bracket price to each available selection.



Where **L** (line) indicates the number of the drawer (from the bottom) and **C** (column) indicates the position on the drawer.

Where **XX** indicates the price line and **VVVVV** the relative price.

Press the **D** and **E** keys to scroll through the available selections.

Press the **F** key to vary the association with the selling price line for the current selection; scroll through the price lines with the **D** and **E** keys, after having selected the desired one, confirm it with the **F** key.

> DISPLAY OF THE SELLING PRICE:

Enables the display of the selling price of the product requested by the customer at the time of the sale. Settable values: **'Enabled'** (ON displayed), **'Disabled'** (OFF displayed).

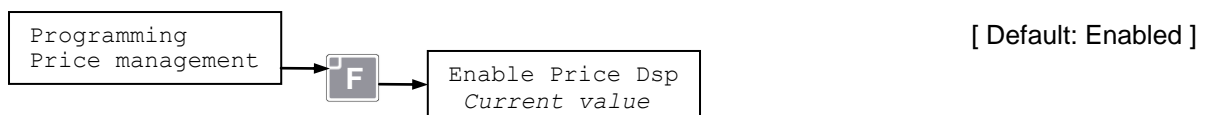

EXECUTIVE PAYMENT SYSTEM PARAMETERS

(Visible and programmable only with 'Operating mode = Executive')

> VALUE OF EACH STEP OR COIN SCALING FACTOR:

The value of the coins and the selling prices are always expressed as multiples of a base coin of minimum value. During operation with Executive payment systems, this value must be the same as the one set in the payment system. Settable values: $0 \div 1000$.

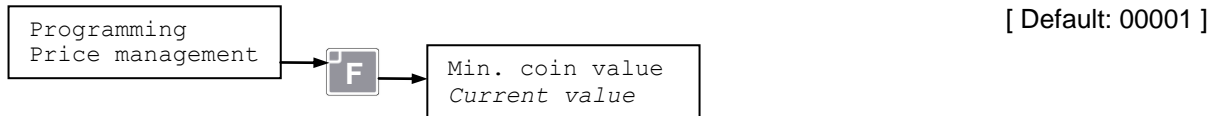

Note 1: if, during entering of the selling prices and of the values of the various coins and banknotes, they are not multiples of the "Value of each step" parameter, they will automatically be rounded off.

MDB PAYMENT SYSTEM PARAMETERS

(Visible and programmable only with 'Operating mode = MDB')

Some of these menus are only visible if a peripheral device is connected that foresees their use.

> MAXIMUM CREDIT:

To set the maximum credit value accepted by the MDB payment system. When the credit in the vending machine reaches this value, the machine no longer accepts coins or banknotes.

Settable values: $0 \div 65535$ (independent of the position of the comma, e.g. with 2 decimals the maximum credit is 655.35). If set to 0, this control is disabled.

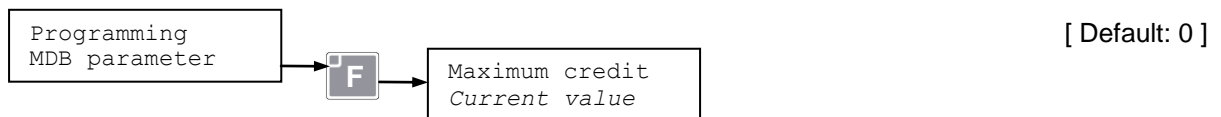

> COIN RETURN PARAMETERS:

If there is an MDB coin return payment system installed in the vending machine, selecting this function it will be possible to set the following operating parameters for it:

» COIN MINIMUM TO INDICATE NO CHANGE AVAILABLE

(Visible and programmable only if 'MDB coin return' payment system installed)

To set the minimum value of the coins that must be present in each individual tube of the MDB coin box below which the vending machine indicates no change available.

Settable values: $0 \div 15$.

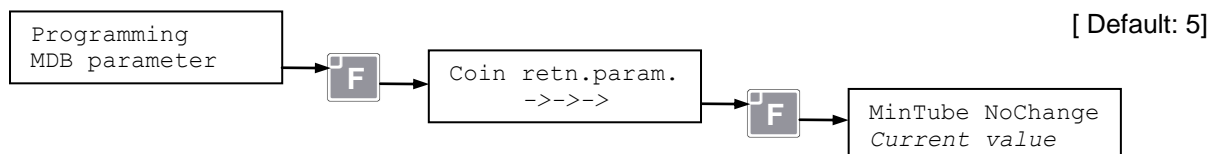

» COIN MINIMUM IN TUBES TO GIVE CHANGE:

(Visible and programmable only if 'MDB coin return' payment system installed)

To set the minimum value of the coins that must be present in the tubes in an MDB payment system below which the vending machine does not give change.

Settable values: $0 \div 5$.

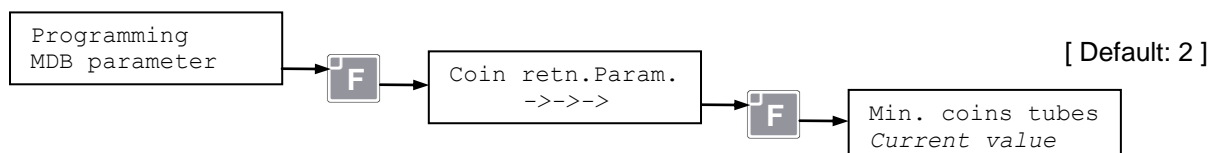

» **COMPULSORY SALE:**

(Visible and programmable only if 'MDB coin return' payment system installed)

If Enabled, the MDB payment system does not give change before a sale, to prevent it from being used as a coin changer. Settable values: 'Disabled' (OFF), 'Enabled' (ON).

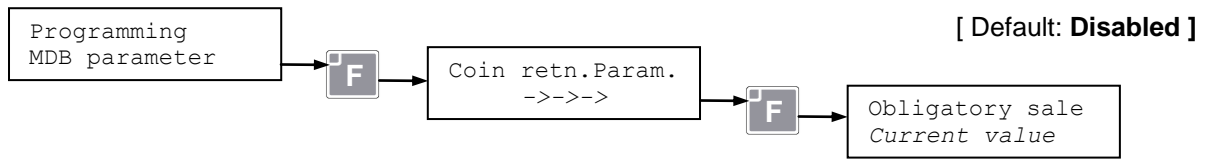

» **MANUAL EMPTYING OF THE COIN TUBES:**

(Visible and programmable only if 'MDB coin return' payment system installed)

If activated it enables the manual emptying of the coin tubes through the pushbuttons on the MDB payment system. Settable values: 'Disabled' (OFF), 'Enabled' (ON).

The emptying of the coin tubes performed by the programming is carried out as described further on:

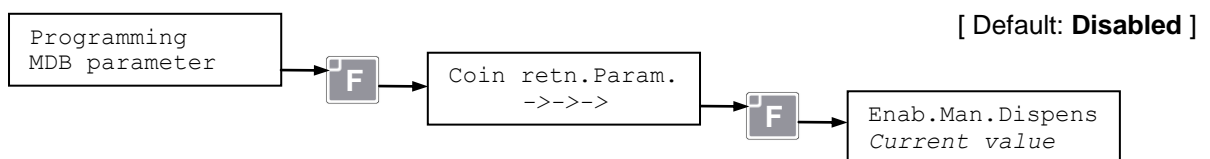

» **MDB SALES MODES:**

(Visible and programmable only if 'MDB coin return' payment system installed)

To select the sales mode with an MDB payment system. Settable values:

'0) Single NoChange', Single sale without change; at the end of the sale the change is cancelled.

'1) Single+Change', Single sale with change; at the end of the sale the change is returned automatically

'2) Multi Vend', Multiple sale: the residual credit is returned only if requested:

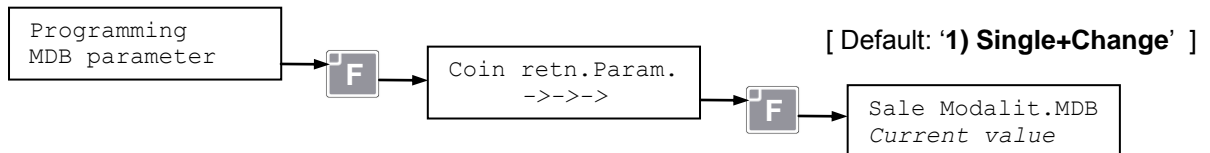

> **COINS AND TUBES:**

If there is an MDB change return coin box installed in the vending machine, it will be possible to set the reading and/or recognition of the quantity and/or value of coins or tokens present in the coin box tubes.

The following coin and tube parameters can be set by selecting this function.

» **COINS MANAGED BY THE COIN RETURN SYSTEM:**

(Visible and programmable only if 'MDB coin return' payment system installed)

To read the value of the coins present in the MDB payment system tubes, and to enable or disable acceptance of these coins; also to empty the coins present in the tubes:

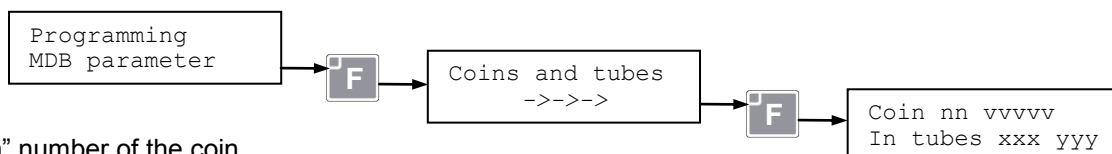

"nn" number of the coin,

"vvvv" value of the coin,

"xxx" number of coins in the tube, if the tube is not enabled it displays "---",

"yyy" =ON coin enabled, =OFF coin disabled

Press the **F** key to enable/disable the coin.

Press the **C** key to manually empty from 1 to 9 coins from the indicated tube.

Note 1: The value of the coins recognised by the payment system depends on the system itself; refer to the relative documentation.

Note 2: With some MDB payment systems the parameter indicating the quantity of coins present could be handled by the payment system itself. Refer to the documentation of the payment system in use.

» **TOKENS PRESENT:**

(Visible and programmable only if 'MDB coin return' payment system that foresees the "Token" function is installed)

To read the number of tokens present in the MDB payment system tubes, and to enable or disable recognition of these tokens:

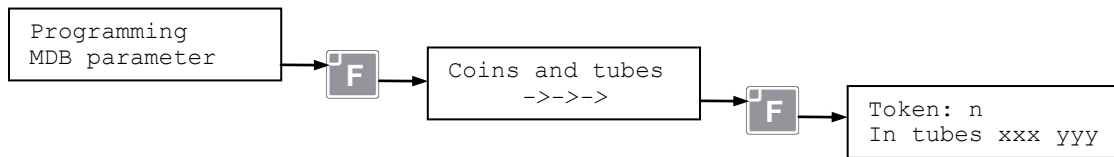

"n" number of the token,
 "xxx" number of tokens in the tube, if the tube is not enabled it displays "---",
 "yyy" =ON token enabled, =OFF token disabled
 Press the **C** key to empty the tube manually

> **BANKNOTES AND STACKER:**

If there is an MDB banknote reader installed in the vending machine, the reading and/or recognition of the quantity and/or value of banknotes or tokens present in the MDB payment system will be possible. The following banknote and stacker parameters can be set by selecting this function.

» **BANKNOTES PRESENT:**

(Visible and programmable only if an "MDB banknote reader" is installed)

To read which and how many banknotes are present in an MDB payment system and to enable recognition of them:

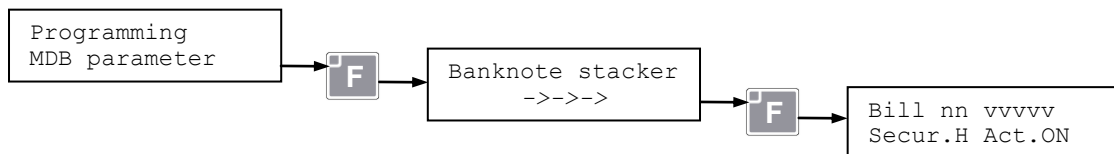

"nn" number of the banknote, "vvvvv" value of the banknote
 "Secur.H" recognition security level high, "Secur.L" low
 "Enabl.ON" banknote enabled, "Enabl.OFF" banknote disabled
 Press **F** to enable/disable the banknote; press **C** to change the recognition security level.

Note 1: The value of the banknotes recognised by the payment system depends on the system itself; refer to the relative documentation.
Note 2: the meaning and operation of the recognition security level depends on the payment system; refer to the relative documentation.

» **TOKEN**

(Visible and programmable only if an "MDB banknote reader" that foresees the "Token" function is installed)

To enable the token recognised by an MDB banknote reader:

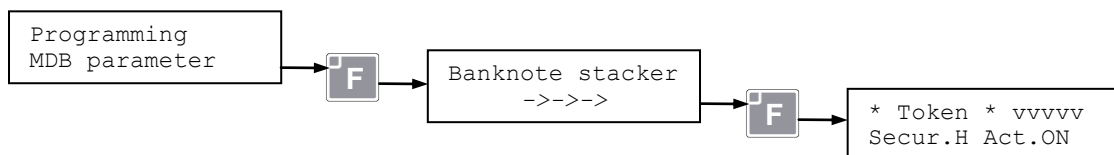

"Secur.H" recognition security level high, "Secur.L" low
 "Enabl.ON" token enabled, "Enabl.OFF" token disabled
 Press **C** to change the recognition security level.
 Press the **F** key to enable/disable the token.
Note 1: the meaning and operation of the recognition security level depends on the payment system; refer to the relative documentation.

> CASHLESS :

If one or more cashless payment systems are installed in the vending machine, it is possible to select the price bracket to be associated with these systems.

» CASHLESS N.1 (PRICE BRACKET ASSOCIATION):

(Visible and programmable only if a 'Cashless payment system' is installed)

If a cashless payment system is installed in the vending machine, it allows selecting the price bracket to be associated with this system. Settable values: 'Prices-A'(Price bracket A), 'Prices-B'(Price bracket B).

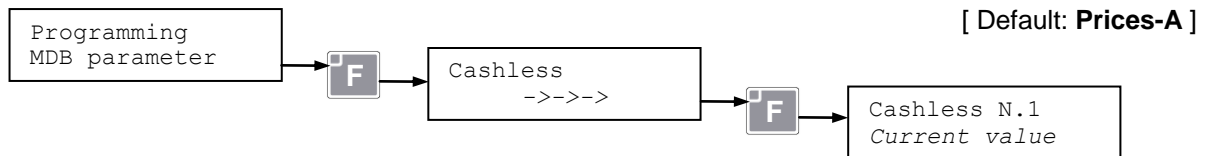

» CASHLESS N.2 (PRICE BRACKET ASSOCIATION):

(Visible and programmable only if a 'Second Cashless payment system' is installed)

If a second cashless payment system is installed in the vending machine, it allows selecting the price bracket to be associated with this system.

Settable values: 'Prices-A'(Price bracket A), 'Prices-B'(Price bracket B).

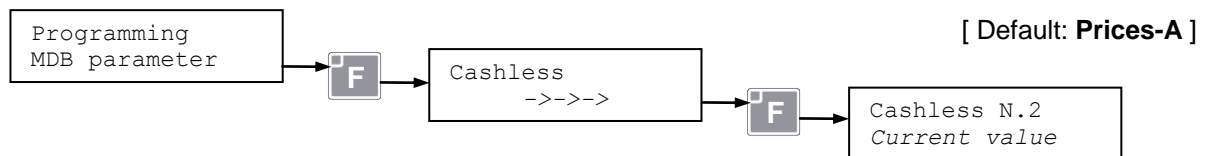

RFID PARAMETERS

(Visible and programmable only if an 'RFID payment system' is installed)

To set the parameters of the RFID payment system.

> RFID – PRICE BRACKET:

If an RFID payment system is installed in the vending machine, it allows selecting the price bracket to be associated with this system.

Settable values: 'Prices-A'(Price bracket A), 'Prices-B'(Price bracket B).

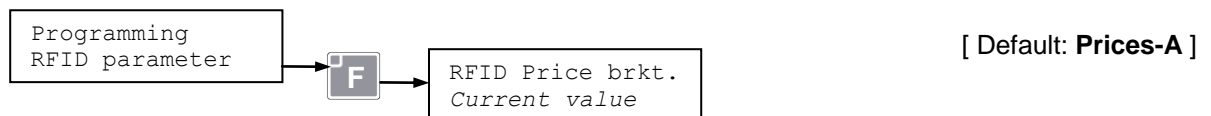

> RFID – MACHINE CODES:

The correct machine codes (Machine code A and B) must be set in the vending machine in order for the RFID payment system to work correctly. Contact the technical assistance service if problems should arise.

REFRIGERATOR PARAMETERS

(Visible and programmable only with 'Refrigerator operation' other than "OFF")

> INTERNAL TEMPERATURE READING:

To read the internal temperature of the vending machine.

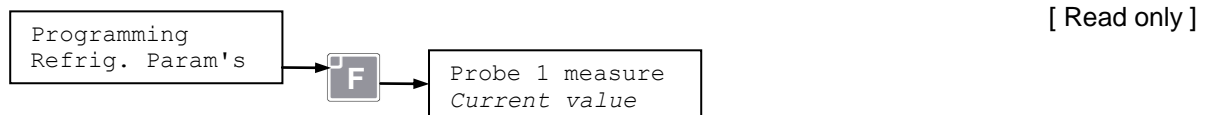

> INTERNAL TEMPERATURE SETTING:

To set the internal temperature of the vending machine; Settable values: 0 ÷ 50°C..

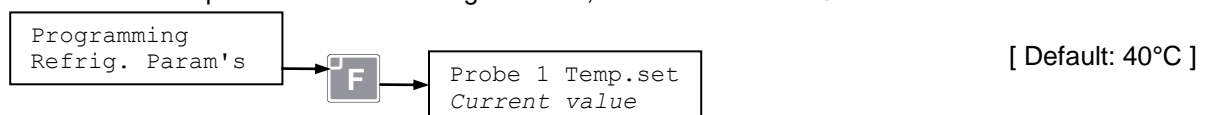

> NIGHT MODE INTERNAL TEMPERATURE SETTING:

(Visible and programmable only with Vivilight Kit installed and "Refrigerator operation" other than "Food & Snack")

This parameter allows setting the internal temperature of the vending machine when the **Night Mode** function is activated. Settable values: **0 ÷ 50°C**.

The refrigerator temperature raising function is deactivated during the **Night-Mode** period if the parameter is set to '0' (Zero) or to a value below the one set as standard internal temperature ('Set Std Temp 1' in the "Refrig. Param's" menu).

This parameter can also be programmed through the "Energy Saving" menu in the "General Param's". Refer to the "Energy Saving" section for further information on this function.

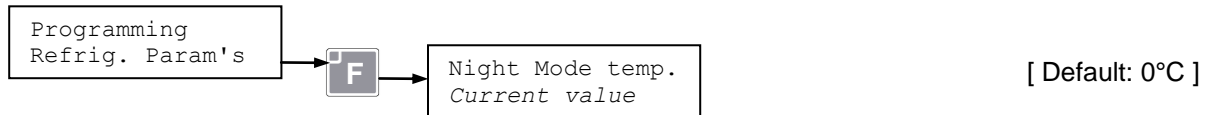

> REFRIGERATION UNIT WORKING TEMPERATURE READING:

(Only visible if 2nd refrigerator probe present)

To read the working temperature inside the refrigeration unit evaporator.

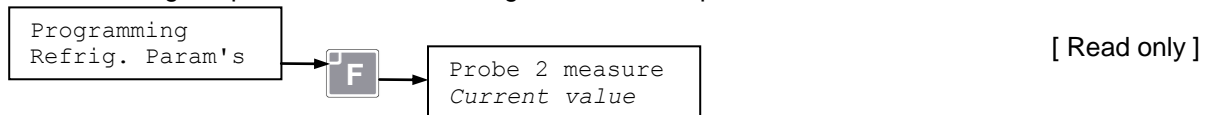

> SAFETY TEMPERATURE:

(Visible and programmable only with 'Refrigerator operation = Food & Snack')

To read the safety temperature for the sale of food products; see the **Overtemperature control** section and the description of the "ERR L09" error message for the description.

Settable values: **0 ÷ 45°C**.

To deactivate this function, set it to $\geq 40^\circ\text{C}$.

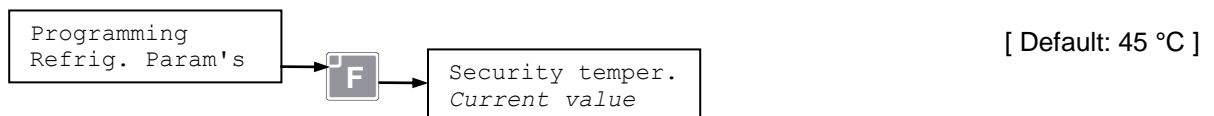

> OVERTEMPERATURE TIME:

(Visible and programmable only with 'Refrigerator operation = Food & Snack')

To set the time beyond which the internal temperature must not exceed the safety temperature; see the **Overtemperature control** section and the description of the "ERR L09" message for the description. Settable values: **0 ÷ 1440** minutes.

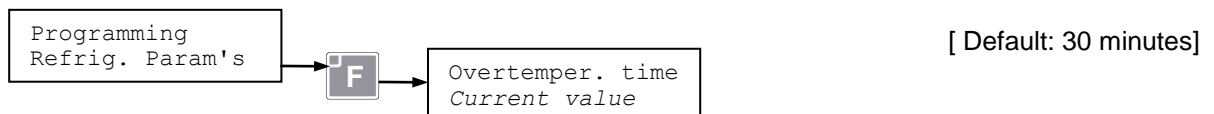

> RESTOCKING TIME:

(Visible and programmable only with 'Refrigerator operation = Food & Snack')

To set the time that is added to the overtemperature time each time restocking takes place (vending machine turned on); see the **Overtemperature control** section for the description. Settable values: **0 ÷ 1000** minutes.

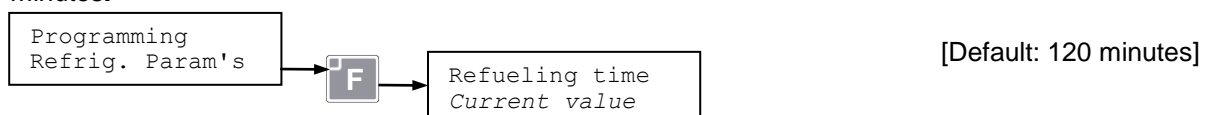

> CONNECTED PROBES:

To read the number of refrigeration unit control probes that are connected.

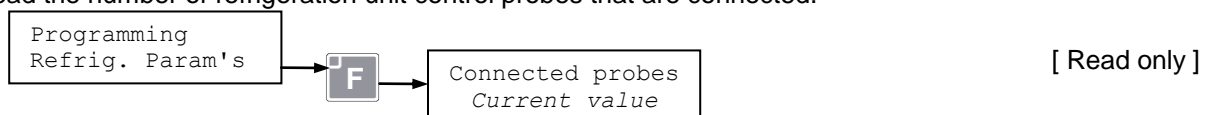

EVA-DTS PARAMETERS

> **PASSWORD CODE RESET (EVA-DTS):**

To reset the "Security" and "Passcode" codes foreseen by the DDCMP protocol (EVA-DTS) to prevent anyone from being able to access and download the data relative to the vending machine proceeds using an IRDA handheld device.



Thanks to these protection codes, the data can be downloaded only if those set on the handheld device coincide with those acquired previously by the vending machine.

If the 2 codes do not correspond, the following error message will appear:

```

    DDCMP error
    9071
  
```

In this case, the codes acquired by the vending machine must be reset (Reset Passcode) by entering the password.

At this point the vending machine has no protection code and will reacquire a new one at the time of the next connection with a handheld device that has a code other than 0 set .

AUDIT PARAMETERS

NOTE: It is possible to display a minimum list of sales data on the automatic vending machine. If an MDB system is installed, the vending machine collects more detailed data, available in the EVA-DTS format.

> **PARTIAL COUNTER OF NUMBER OF VENDING MACHINE SALES:**

To read the total number of vending machine sales since the last reset.

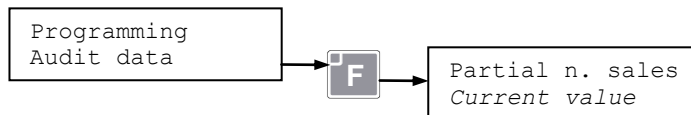

> **PARTIAL COUNTER OF VALUE OF VENDING MACHINE SALES:**

To read the total amount collected by the vending machine since the last reset.

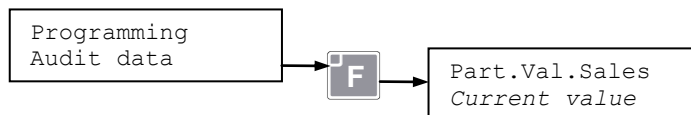

» **COUNTER OF NUMBER OF SALES PER SELECTION:**

To read the total (absolute and partial since the last reset) number of sales for each individual vending machine selection.

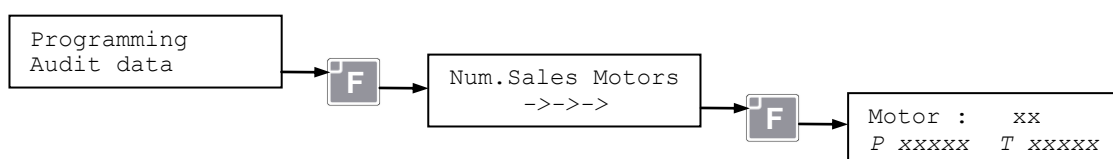

» **COUNTER OF NUMBER OF SALES PER LINE (SALES PRICE):**

To read the total (absolute and partial since the last reset) number of sales for each product price line.

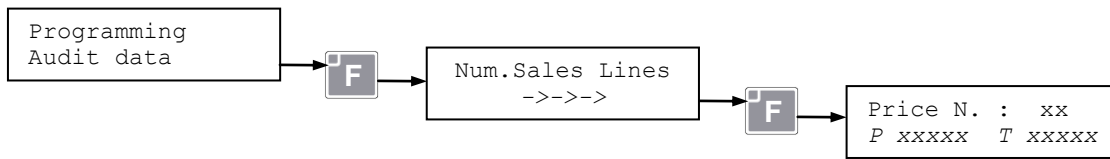

> **GENERAL TOTAL NUMBER OF VENDING MACHINE SALES:**

To read the general total number of vending machine sales:

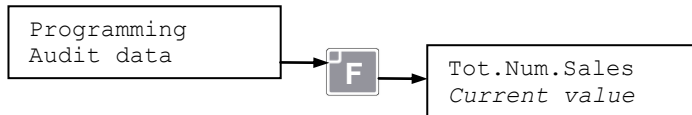

> **GENERAL TOTAL VALUE OF VENDING MACHINE SALES:**

To read the general total of the amount collected by the vending machine:

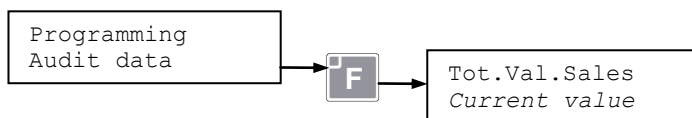

» **AUDIT DATA RESET:**

To reset the Partial totals counted by the vending machine.



DIAGNOSTICS

N.B. the programming TimeOut is disabled in the Diagnostics submenus, therefore, it is only possible to exit programming manually, using the appropriate keys.

> **OUT OF ORDER MOTORS:**

Select this item to see which motors have generated an Out of Order condition. The out of orders are also listed in this menu

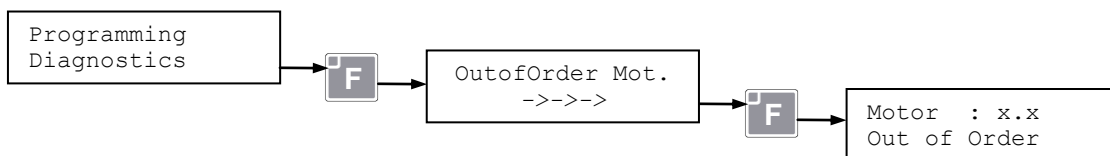

The following message will appear if there are no motors out of order:

```

    No motor
    Out of Order
  
```

If there are motors out of order, you can use the **D** and **E** keys to scroll through the list of motors; the current motor will be activated when the **F** key is pressed; the following message will appear if there is still a malfunction:

```

    Error
    xxxxxx
  
```

Where "xxxxxx" is the detected error. See the "Installation and service" manual, "Problems and relative solutions" chapter, "Motor anomaly messages" section for the list of anomalies and relative solutions. It is important to keep in mind that even possible out of orders that are automatically reset (R) by turning the vending machine on and off are also listed in this menu (see "Motor anomaly messages" chapter indicated above). The indication remains until the out of order has been reset as indicated below.

Press the **C** key to cancel the Out of Service condition of the current motor. The following message will appear on the display:

```
Motor : x.x
Reset
```

Press the **A** key to exit the submenu.

NOTE: It is possible to cancel all of the "Out of Order" conditions of the motors without entering into programming by pressing the PS2 key found on the CPU card for approx. 3 seconds (See Page A-2).

> **MANUAL MOTOR TEST:**

Select this item to test the individual motors, making them carry out a sales cycle.

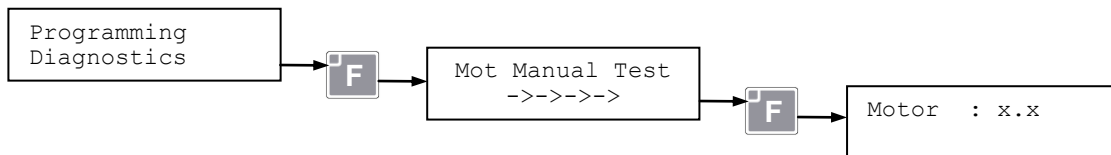

Use the **D** and **E** keys to scroll through all of the motors detected during the self-learning procedure. When the **F** key is pressed briefly, the current motor will be activated; the following message will appear if a malfunction occurs:

```
Error
xxxxxx
```

Where "xxxxxx" is the detected error. See the "Installation and service" manual, "Problems and relative solutions" chapter, "Motor anomaly messages" section for the list of anomalies and relative solutions.

The general test cycle will begin instead when the **F** key is kept press for about one second; during this cycle, the vending machine will carry out a sales cycle in sequence for each gearmotor detected by the self-learning procedure, starting from the current motor up to the last motor of the vending machine. In the event of a defect on one of the motors, the test will be interrupted and the relative error message displayed.

The general test cycle will be interrupted when keeping any key pressed until the end of the sales cycle of the current motor.

Press the **A** key to exit the submenu.

> **MOTOR VERIFY:**

Select this item to perform a quick check of the condition of the motors. This function does not change the vending machine configuration detected during the self-learning procedure; it simply limits itself to comparing the current condition of the motors with that of the last self-learning procedure performed.

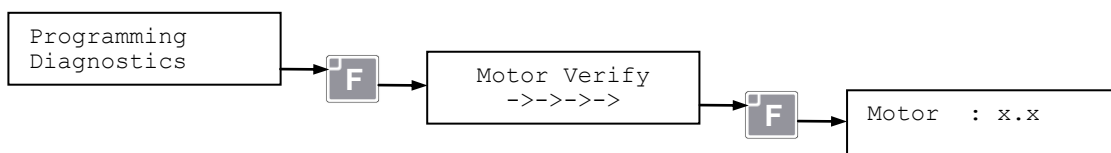

[Where x.x scrolls the motors in sequence]

If errors should be detected during the check, the check itself stops and the following message appears:

```
Error
xxxxxx
```

Where "xxxxxx" is the detected error. See the "Installation and service" manual, "Problems and relative solutions" chapter, "Motor anomaly messages" section for the list of anomalies and relative solutions.

From these error conditions it is possible to make the check sequence continue by pressing the **F** key, or end it with the **A** key.

One of the following messages will appear at the end of the check sequence:

```
Check incorrect
Conn. motors: XX
```

This means that anomalies and/or differences between the current configuration and the one detected during the last self-learning procedure have been detected; XX indicates the number of the currently recognised motors.

```
Check OK
Conn. motors: XX
```

This means instead that anomalies and/or differences between the current configuration and the one detected during the self-learning procedure have not been detected; XX indicates the number of the recognised motors.

In the event of "Check OK", at the end of the motor check cycle the vending machine's original configuration is completely restored and the out of orders reset.

N.B.: at each check the motors rotate just a few degrees; therefore, repeating the check several times in succession, the motors could lose alignment; we therefore recommend realigning the motors, for example by carrying out a manual motor test, as described previously in this manual.

> MOTOR SELF-LEARNING:

Select this item to repeat the self-learning of the motors present in the vending machine; this action is only allowed if a password is set in the protected parameters menu.

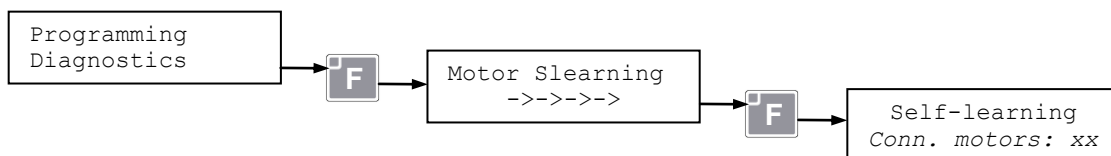

> **SLIDING PANEL TEST**

Select this item to perform the sliding anti-theft panel operation test.

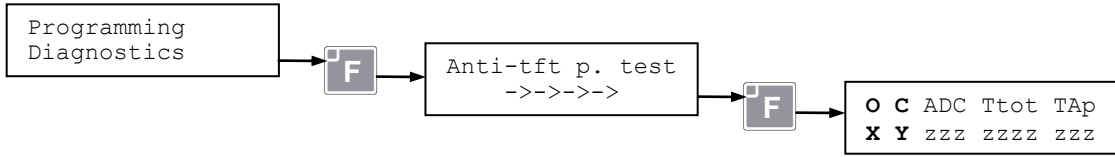

When the following message appears on the display:

O	C	ADC	Ttot	TAp
X	Y	zzz	zzzz	zzz

Parameter **O** → Panel open microswitch **X = 1** pressed **X = 0** not pressed.
 Parameter **C** → Panel closed microswitch **Y = 1** pressed **Y = 0** not pressed

Press the **1** key to open the anti-theft panel.
Press the **2** key to close the anti-theft panel.

If automatic calibration of time/speed of opening/closing of the sliding panel is needed press **9** key for 2 seconds, the sliding panel will perform some opening/closing cycles:
At the end of the test, the following message will appear on the display:

O:xxx	C:xxx	Pxxx
TO:xxxx	TC:xxxx	

Press any key to quit the test.

If a diagnosis of the sliding panel motor is needed, press **8** key for 2 seconds: the sliding panel will perform some opening/closing cycles.

At the end of the test the following message will appear on the display:

Open:	X	zzzz	zzzz
Clos:	Y	zzzz	zzzz

X and **Y** values equal or superior to 5 induce a good efficiency of the motor.
X and **Y** values inferior to 5 induce a low efficiency of the motor.
 Motor works as well, but it is necessary to make the following controls in order to avoid future damages:
 Check that the sliding panel can slide freely, that guides are clean and that there is nothing that reduces the sliding speed, eventually provide to lubricate sliding panel rack and pinion.
 If repeating the test one of **X** and **Y** values is still less than 5 it is advisable to provide replacement of the motor in a short time.

Press the **A** key to exit the submenu.

> **"PUSH" PRODUCT REMOVAL DOOR TEST**

Select this item to perform the "Push" product removal door operation test.

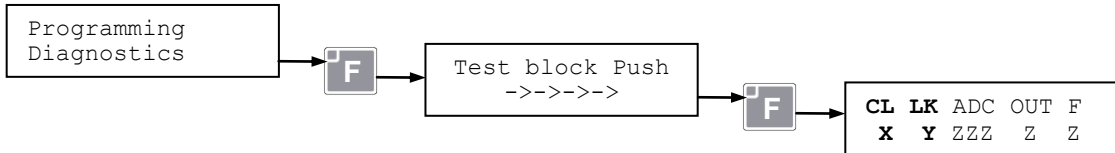

When the following message appears on the display:

CL	LK	ADC	OUT	F
X	Y	ZZZ	Z	Z

Press the **F** key to unlock the "Push" product door for 10 seconds.
Press the **F** key again to relock the "Push" product door.

Parameter **CL**

X = 1 "Push" product door closed.

X = 0 "Push" product door open.

Parameter **LK**

Y = 1 "Push" product door locked (i.e. the microswitches located on the magnets indicate they are raised).

Y = 0 "Push" product door unlocked.

Press the **A** key to exit the submenu.

> **VENDING SENSOR TEST (FTCA)**

Select this item to test the vending sensor circuit (FTCA).

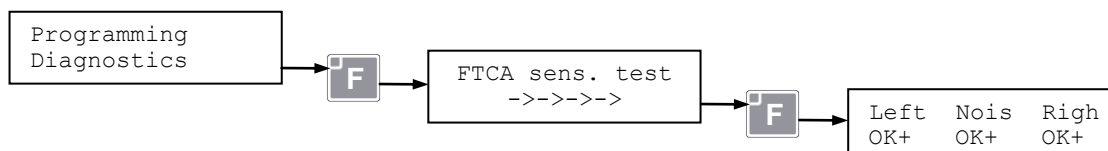

The following message will appear on the display:

Left	Nois	Righ
OK+	OK+	OK+

The "Left" and "Right" parameters indicate the degree of intensity of the light detected by the sensors. The "Nois" parameter indicates the level of intensity of the noise detected by the sensors.

We understand the "status" of the FTCA system through these three parameters.

Possible values:

OK+ : The level is good

OK : The level is fair

OK - : The level is minimal but sufficient

ERR : The level is insufficient

If one of the three parameters should be at the "ERR" level, the FTCA infrared system will be out of order and an "OFF L10..." message will be displayed (see OFF message table for details).

When the following message appears on the display:

Left	Nois	Righ
OK+	OK+	OK+

The following message will appear when the **F** key is pressed:

FTCA 2 Enabled
Mot:yy Sens:xxx

When the **F** key is pressed it will be possible to carry out a test delivery (sale) on the yy selection.

For each product delivered (sold) a "beep" will be emitted each time an object passes in front of the sensors and a different value will appear on the display in the "Sens" field; through this information we understand that the FTCA system works correctly; the higher the number (Sens), the easier it will be for the FTCA infrared system to detect the delivered product.

Press the **D** and **E** keys to change the selection indicated by the "Mot" parameter.

Press the **A** key to exit the submenu.

Summary table:

(*) Memorandum to be filled out after the programming under way

Menu	Parameter	Meaning	Min-Max	Default	Adjusted to (*)
General Param's	Language	Message language		Italian	
General Param's	Operating mode	Operating mode		MDB	
General Param's	DDD DD/mm hh:mm	Clock setting			
General Param's	DateTime Dsp Enable	Clock enable	Enabled - Disabled	Enabled	
General Param's	SaveMode delay	Activation delay in SaveMode	0 ÷ 120 minutes	0	
General Param's	Light in SaveMode	Light intensity in SaveMode	0 ÷ 100%	100%	
General Param's	NightMode timetable	NightMode Activation Timetable		19:00÷7.00	
General Param's	NightMode Light	Light intensity in NightMode	0 ÷ 100%	100%	
General Param's	NightMode temp.	Temperature setting in NightMode	0 ÷ 50 °C	0	
General Param's	Refrigerator operation	Refrigerator Operation		Aut.	
General Param's	FTCA enabling	Vending sensor enabling	0)Disabled, 1)Enable Nostep, 2)Enable +3step	2)Enable + 3step	
General Param's	FTCA max 3 sel.	FTCA max 3 selections	Enabled - Disabled	Enabled	
General Param's	Decimal point	Decimal point position	0 ÷ 3	2	
General Param's	Code Mode	Internal code software	Read only		
General Param's	Software versions	Displays software versions			
General Param's	Default P. Reset	Card reinitialisation	Password required		
General Param's	Protected param.	Protected parameters	Password required		
Reset Temp.	---	Reinitialise overtemperature times			
Price management	Price-A N.:xx	Value of each of the 44 associable 'A' bracket prices	0 ÷ 635.35	2.00	----
Price management	Price-B enabling	Enabling 'B' price bracket	Enabled - Disabled	Disabled	
Price management	Price-B N.:xx	Value of each of the 44 associable 'B' bracket prices	0 ÷ 635.35	2.00	----
Price management	Drawer L-C	Price associated with drawer (Line) L , (column) C	0 ÷ 44	01	----
Price management	Enable Price Dsp	Display of the selling price	Enabled - Disabled	Enabled	
Executive parameters	Min. coin values	Coin scaling factor	0 ÷ 1000	000.01	
MDB parameters	Maximum credit	Maximum accepted credit	0 ÷ 635.35	0	
MDB parameters	MinTube NoChange	Minimum coins to turn "no change" indicator light on		5	
MDB parameters	MinTube Change	Minimum coins for giving change		2	
MDB parameters	Obligatory Sale	Compulsory sale	Enabled - Disabled	Disabled	
MDB parameters	Enab. Man. Dispens	Manual emptying of the coin tubes	Enabled - Disabled	Disabled	
MDB parameters	Sale Modalit. MDB	MDB sales modes	0)Single no Chang 1)Single+Change 2)Multi Vend	1)Single+ Change	

(*) Memorandum to be filled out after the programming in progress

Menu	Parameter	Meaning	Min-Max	Default	Adjusted to (*)
MDB parameters	Coin nn vvvvv In tubes xxx yyy	Coins present			
MDB parameters	Token: n In tubes xxx yyy	Tokens present			
MDB parameters	Bill nn vvvvv Secur.X Act.ON	Banknotes present			
MDB parameters	* Token * vvvvv Secur.H Act.ON	Token			
MDB parameters	Cashless N.1	Cashless n.1 price association	Prices-A, Prices-B	Prices-A	
MDB parameters	Cashless N.2	Cashless n.2 price association	Prices-A, Prices-B	Prices-A	
RFID parameters	RFID - Price bracket	RFID price Association	Prices-A, Prices-B	Prices-A	
Refrig. Param's	Probe 1 measure	Internal temperature reading	Read only		
Refrig. Param's	Set probe 1 temperature	Internal temperature setting	0 ÷ 50 °C	40	
Refrig. Param's	NightMode temp.	Temperature setting in NightMode	0 ÷ 50 °C	0	
Refrig. Param's	Probe 2 measure	Refrigeration Unit temperature reading	Read only		
Refrig. Param's	Security Temper.	Safety temperature	0 ÷ 45 °C	45	
Refrig. Param's	Overtemper. Time	Overtemperature time	0 ÷ 1440 min.	30	
Refrig. Param's	Refueling time	Restocking time	0 ÷ 1000 min.	120	
Refrig. Param's	Connected probes	Number of connected refrigerator probes	Read only		
EVA-DTS parameters	Reset passcode	Reset Security and Passcode codes	Password required		
Audit data	Part. Sale Numb.	Partial counter of number of vending machine sales	Read only		
Audit data	Part. Sale Value	Partial counter of value of sales of the selections	Read only		
Audit data	Motor Sale Numb.	Counter of number of sales per selection:	Read only		
Audit data	Sale Numb. Lines	Counter of number of sales per price line	Read only		
Audit data	Tot. Sale Numb.	General total number of vending machine sales	Read only		
Audit data	Tot. Sale Value	General total value of vending machine sales	Read only		
Audit data	Audit Data Reset	Audit data reset	Password required		
Diagnostic	Motors Out of Ord.	Search for out of order motors	---		
Diagnostic	Manual MotorTest	Motor sales cycle test	---		
Diagnostic	Motor Verify	Quick motor test	---		
Diagnostic	Motor Slearning	Motor config. self-learning	Password required		
Diagnostic	Test anti. panel	Sliding anti-theft panel test	---		
Diagnostic	Test block Push	"Push" product door test.	---		
Diagnostic	FTCA sensor test	Vending sensor test	---		

NOTE: "Default" = Value used automatically by a new unprogrammed or reinitialised card.

EC DECLARATION OF CONFORMITY

Damian S.r.l.
Via Ragazzi del '99 n°30
21053 Castellanza
Varese Italy

Declaration not valid
without the
identification plate

Tel. +39 0331 322020
Fax +39 0331 322030

Dichiara che la macchina descritta nella targhetta di identificazione è conforme alle disposizioni legislative

delle seguenti Direttive: **2006/95 CE e 2004/108 CE;**

delle seguenti norme: **EN 60335-1:2002 + A1:2004 + A11:2004 + A12:2006**

EN 60335-2-75:2004 + A1:2005 + A11:2006

EN 55014-1:2000 + A1:2001 + A2:2002, EN55014-2:1997 + A1:2001

EN 55015:2002 + A1:2001 + A2:2002, EN 61547:1995 + A1:2000

EN 61000-3-2:2000 + A2:2005, EN 61000-3-3:1995 + A1:2001 + A2:2005

EN 50366:2003 + A1:2006.

e soddisfa i requisiti essenziali della Direttiva: **98/37 CE;**

Declares that the machine described on the identification plate is in conformity with the legislative provisions

of the following Directives: **2006/95 CE and 2004/108 CE;**

of the following regulations: **EN 60335-1:2002 + A1:2004 + A11:2004 + A12:2006**

EN 60335-2-75:2004 + A1:2005 + A11:2006

EN 55014-1:2000 + A1:2001 + A2:2002, EN55014-2:1997 + A1:2001

EN 55015:2002 + A1:2001 + A2:2002, EN 61547:1995 + A1:2000

EN 61000-3-2:2000 + A2:2005, EN 61000-3-3:1995 + A1:2001 + A2:2005

EN 50366:2003 + A1:2006.

and satisfies the basic requirements of Directive: **98/37 CE;**

Castellanza, 21 February 2007

damian 

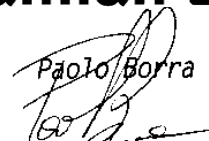
Paolo Borra

Presidente C.d.A.
Managing Director

GENERAL WARRANTY CONDITIONS

In compliance with the laws, the device is guaranteed for **12 (twelve) months** from the purchase date confirmed by a delivery document issued by the manufacturer.

By warranty we mean the free of charge repair or the replacement, on the manufacturer's premises, of those parts of the device recognised as faulty because of defects in manufacturing.

The faulty parts will be sent back by the customer, ex manufacturing works. If some parts under warranty must be repaired or replaced on the customer's premises by personnel sent by the manufacturer, the labour costs and travel expenses will be charged to the customer.

The warranty does not cover those parts which are faulty because of negligence or carelessness, incorrect installation or maintenance, wear and tear caused by excessive use, maintenance operations carried out by unskilled workers, transport, i.e. caused by events not due to defects in manufacturing of the device. Technical operations relative to the installation and connection of the device to the power supply systems are not included in the warranty either.

Damian S.r.l. is not responsible for possible injuries and damage to persons or objects caused directly or indirectly by the lack of observance of the instructions given in this manual and of any other information transmitted by the manufacturer to the customer, concerning, above all, the warnings/cautions relative to **installation, use and maintenance of the device**.

Replacement of the device and prolongation of the warranty following the occurrence of a breakdown are excluded.

Technical modification reservation

To constantly improve the quality of our products and to guarantee an ever higher level of safety and environmental protection, Damian S.r.l. reserves the right to change the technical and construction characteristics of its own products without advance notice.

Damian S.r.l. reserves the right to inform its customers through information bulletins, updating of manuals, communications or other information means that it considers appropriate of all of the changes regarding safety or environmental protection and all other information which turns out to be useful.